

**D**

## Einbauanleitung PSL Modell 4

für elektrische Stellantriebe PSL201-214 + PSL202-214/AMS

**AE**

## Installation Instructions PSL Model 4

for electric actuators PSL201-214 + PSL202-214/AMS

**E**

## Instrucciones de montaje PSL Versión 4

por actuadores eléctricos PSL201-214 + PSL202-214/AMS



<b>D</b>	<b>Inhaltsverzeichnis</b>	<b>3</b>
	1. Sicherheit	
	2. Bezeichnungen	
	3. Montage	
<b>AE</b>	<b>Table of content</b>	<b>5</b>
	1. Safety	
	2. Designations	
	3. Mounting	
<b>E</b>	<b>Indice</b>	<b>7</b>
	1. Seguridad	
	2. Denominación	
	3. Montaje	

# D

## 1. Sicherheit



Während des Aufbaus den Antrieb nur mit dem Handrad verfahren!

Bei Nichtbeachtung: Quetschgefahr, Beschädigung von Antrieb und/oder Armatur.

**Wichtig!** ZUR MONTAGE MUSS SICH DIE VENTILSPINDEL IN VOLL EINGEFAHRENER POSITION BEFINDEN.

Die Gebäudeinstallation sowie die Überstromsicherheit und Überspannungsschutzeinrichtungen müssen entsprechend der Norm DIN IEC 60364-4-41, Schutzklasse I bzw. Schutzklasse III bei 24VAC/24VDC sowie DIN IEC 60364-4-44 entsprechend der verwendeten Überspannungskategorie des Antriebs ausgeführt sein.

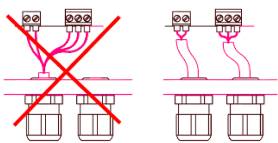

Alle Netzanschluss- und Steuerleitungen müssen mechanisch durch geeignete Maßnahmen vor den Anschlussklemmen gegen unabsichtliches Lösen gesichert werden. Netzanschluss und Steuerleitungen dürfen nicht zusammen in einer Leitung geführt werden, es sind stets zwei getrennte Leitungen zu verwenden!

Hinweis: Bildlich wird die Montage eines PSL202 gezeigt, die Schritte sind jedoch bei allen Modellen identisch!

## 2. Bezeichnungen

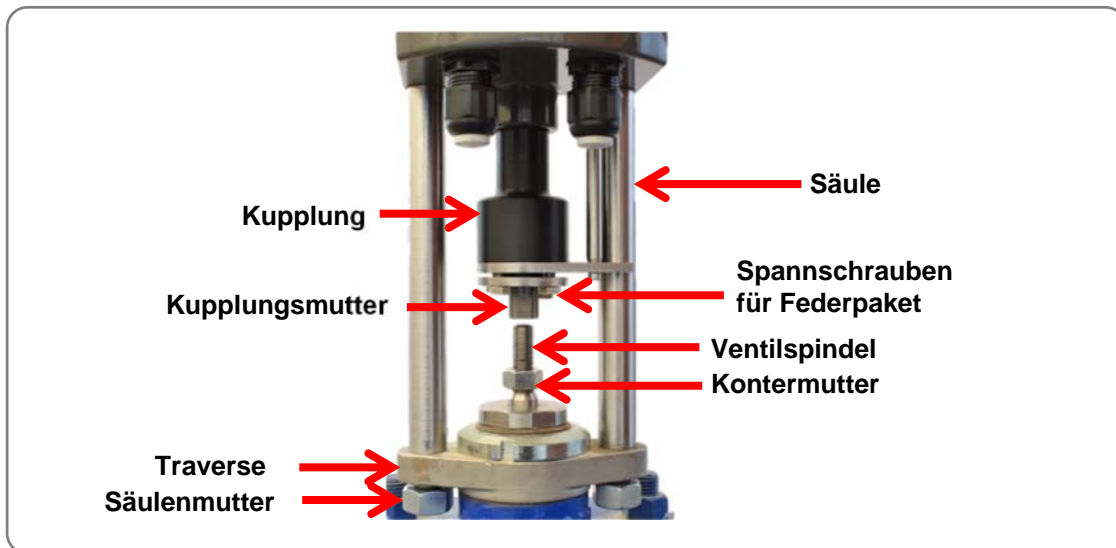

## 3. Montage

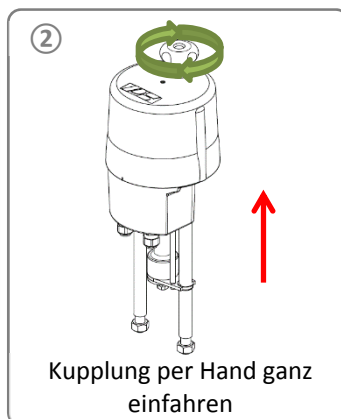

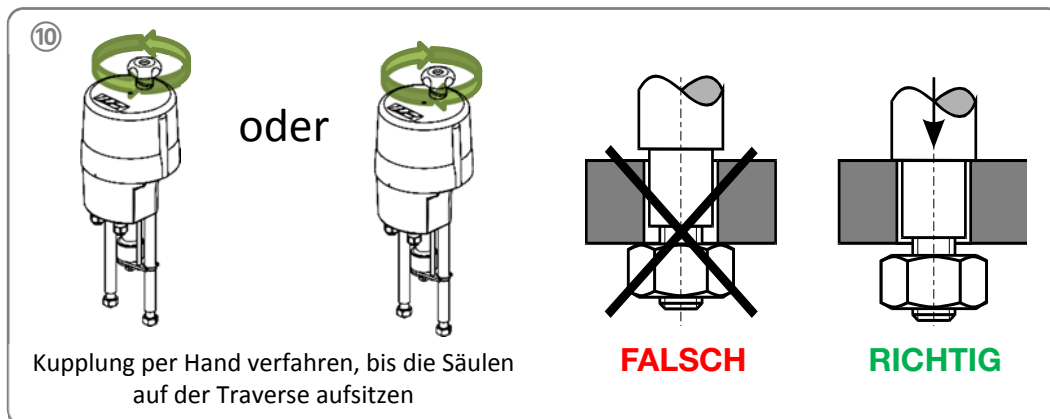
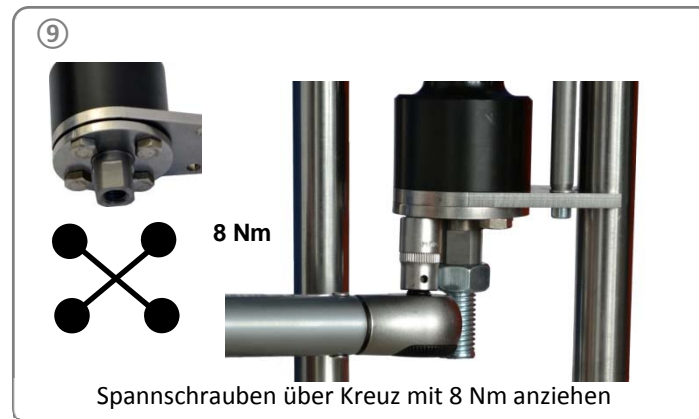
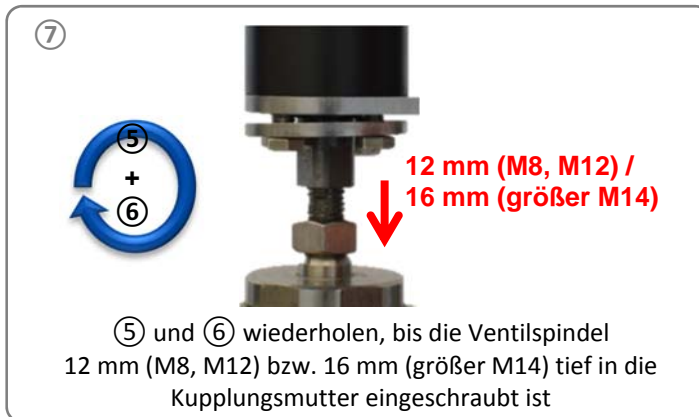
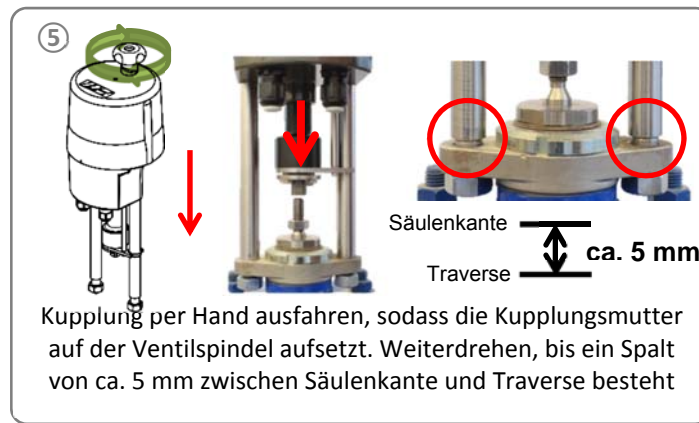
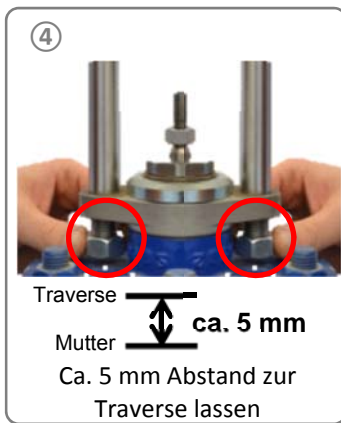

Bei Fragen zur Montage helfen wir Ihnen gerne weiter!

Tel.: +49 (0) 6322 / 6003 - 0

Mail:

info@ps-automation.com



## 1. Safety



When mounting an actuator on a valve, always use the hand wheel! Motor operation during mounting may cause injuries and damage to actuator and valve!

**FOR MOUNTING THE ACTUATOR, THE VALVE MUST BE IN FULLY CLOSED POSITION!**

**Important!**

Electric installation as well as over-current and overvoltage protection devices must conform to the standard DIN DIN VDE 0100-410, protective class I resp. protection class 3 (24VAC/24VDC) and also to the standard DIN IEC 60364-4-44 according to the applied overvoltage category of the actuator.

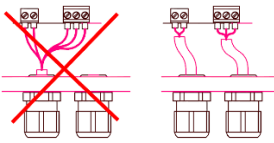

Please protect all of the power supply and control cables in front of the terminals mechanically by using suitable measures against unintentional loosening. Never install the power supply and the control cables together in one line but instead please always use two different lines.

## 2. Designations

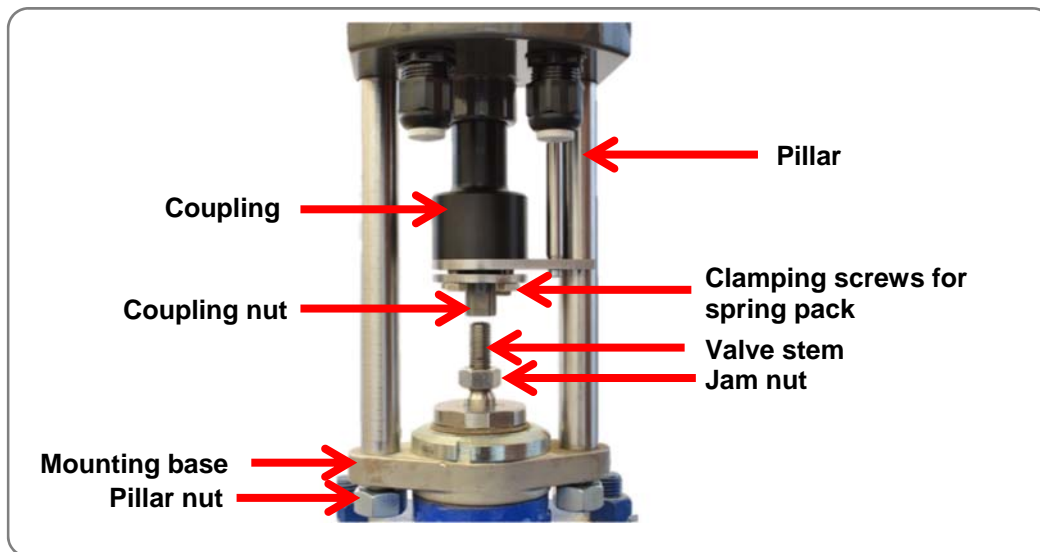

## 3. Mounting

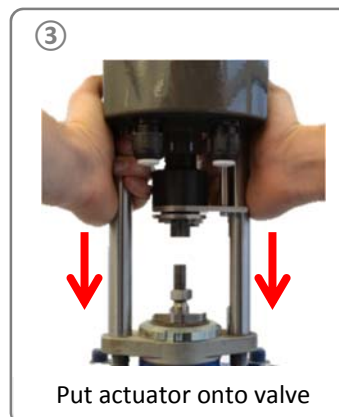
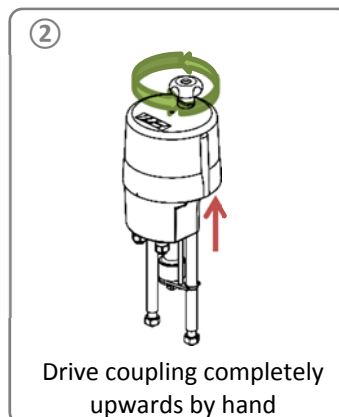

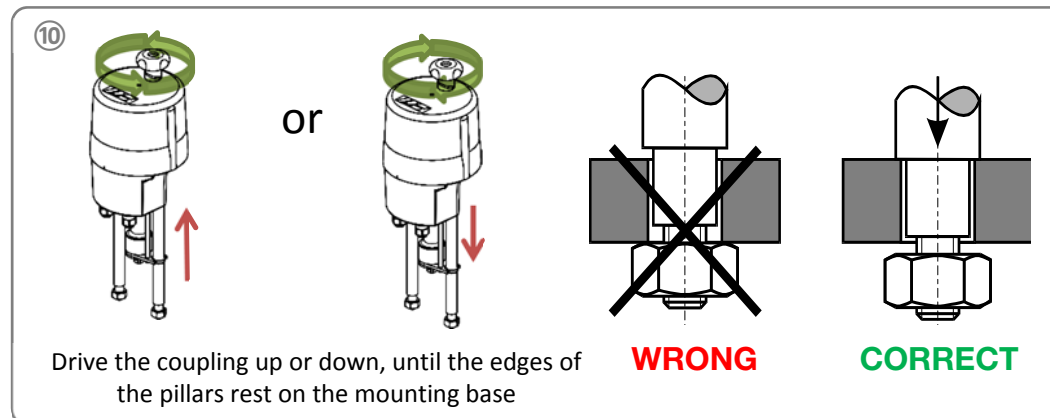
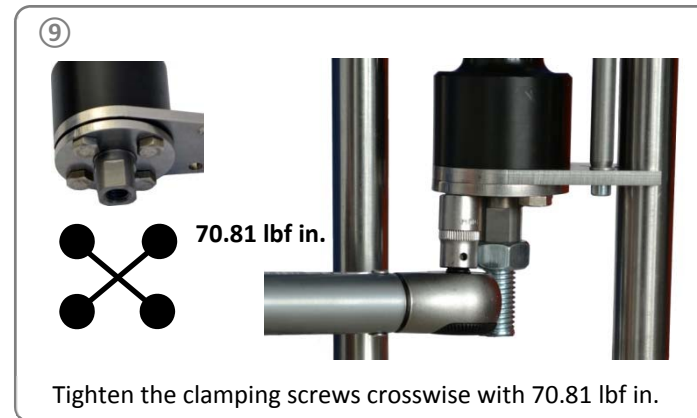
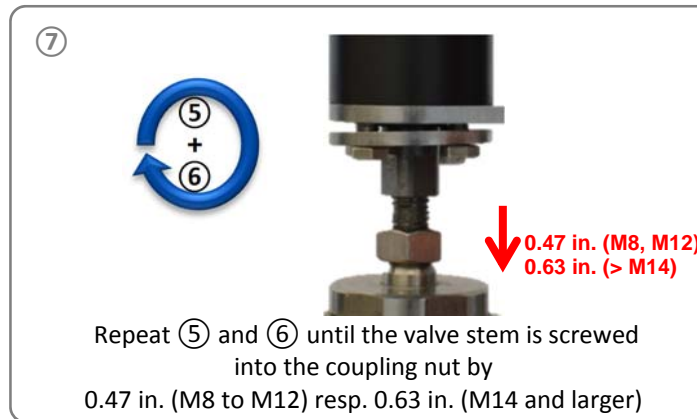
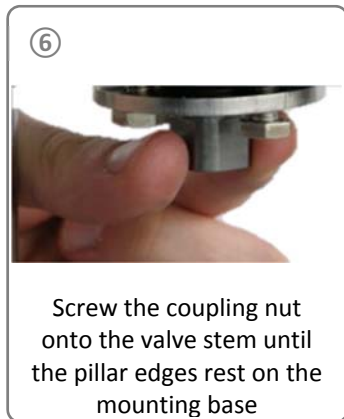
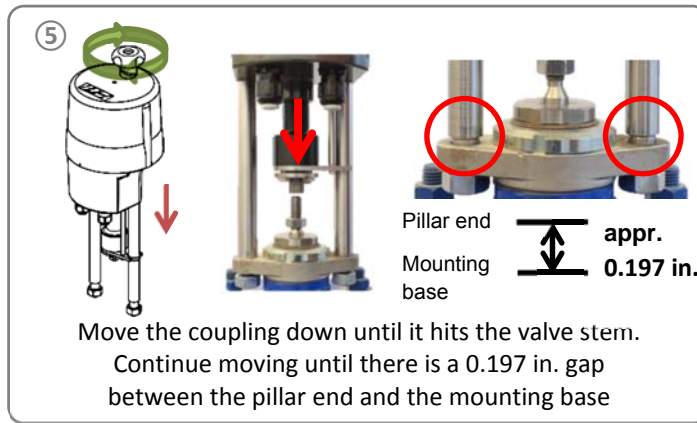
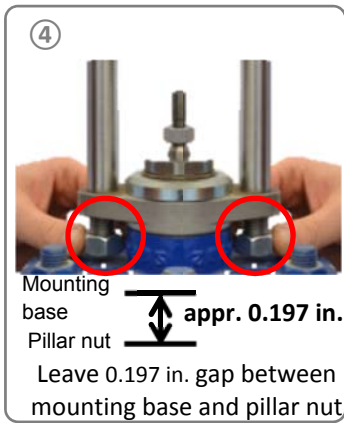

In case of any question, please do not hesitate to contact us:

Phone: +49 (0) 6322 / 6003 - 0

Mail: [info@ps-automation.com](mailto:info@ps-automation.com)





## 1. Seguridad



Quando realice el montaje del actuador sobre la válvula siempre debe utilizar el volante. La utilización del motor durante el montaje puede causar serios daños al actuador y a la válvula.

**Importante!**

**PARA EL MONTAJE DEL ACTUADOR, LA VALVULA DEBE ESTAR EN POSICION COMPLETAMENTE CERRADA!**

La instalación del edificio así como el dispositivo de protección y los supresores de sobretensión deberán corresponder a la norma DIN IEC 60364-4-41, clase de protección I o bien clase de protección III a 24VAC/24VDC así como DIN IEC 60364-4-44 en consonancia con el Categoría del actuador.

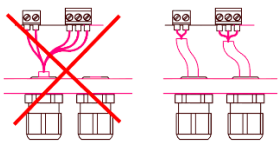

Todos los cables de alimentación y de mando deben protegerse mecánicamente mediante unas medidas adecuadas para evitar que se suelten involuntariamente. Los cables de alimentación y de mando no pueden pasar juntos en una línea eléctrica. Utilizar dos cables separados.

## 2. Denominación

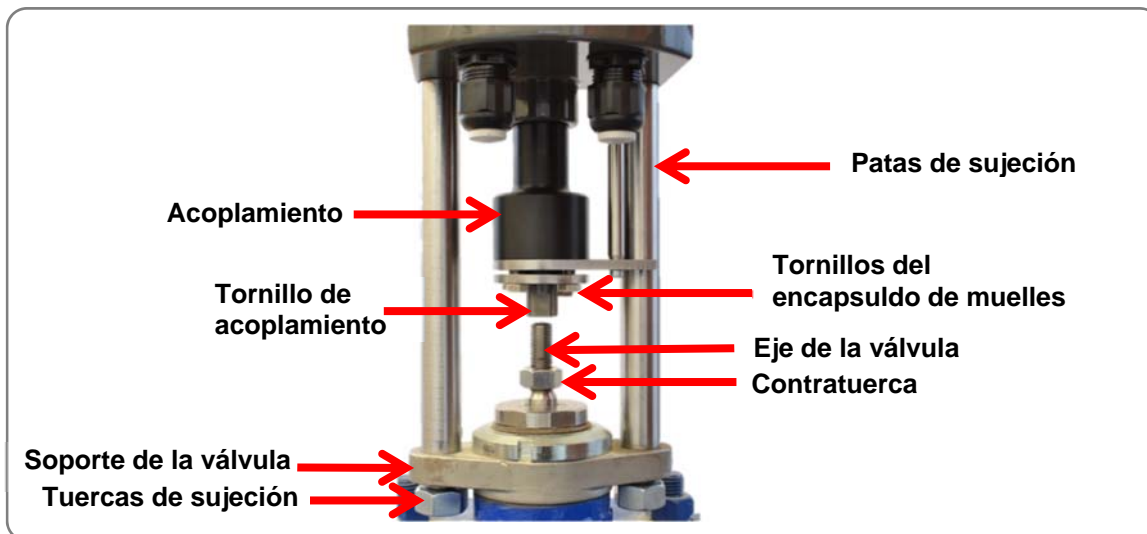

## 3. Montaje

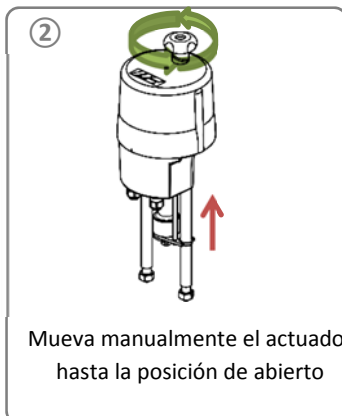

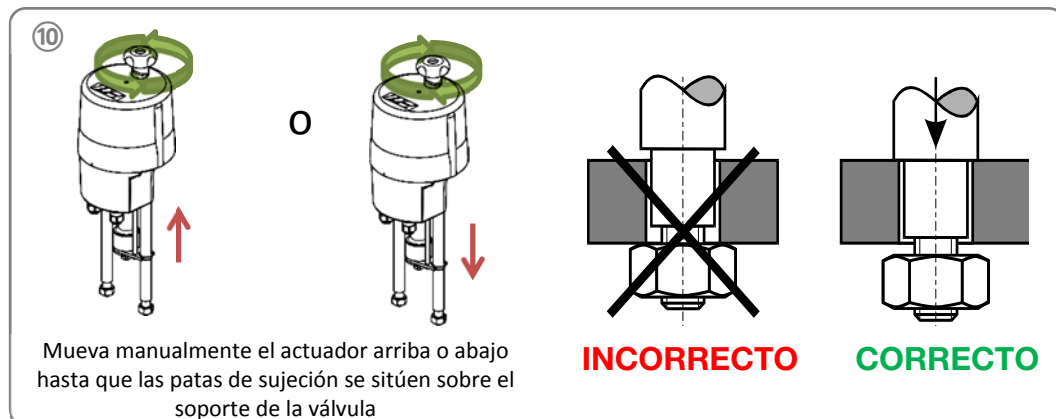
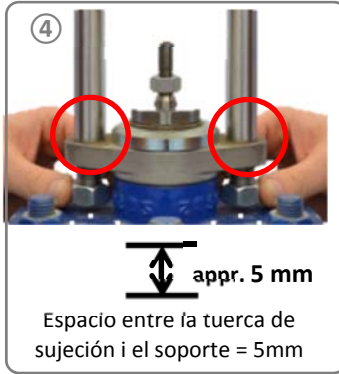

En casa de preguntas, por favor contacto:

Phone: +49 (0) 6322 / 6003 - 0

Mail: [info@ps-automation.com](mailto:info@ps-automation.com)