

Operating Instructions

PS-AMS1x PSL Model 4

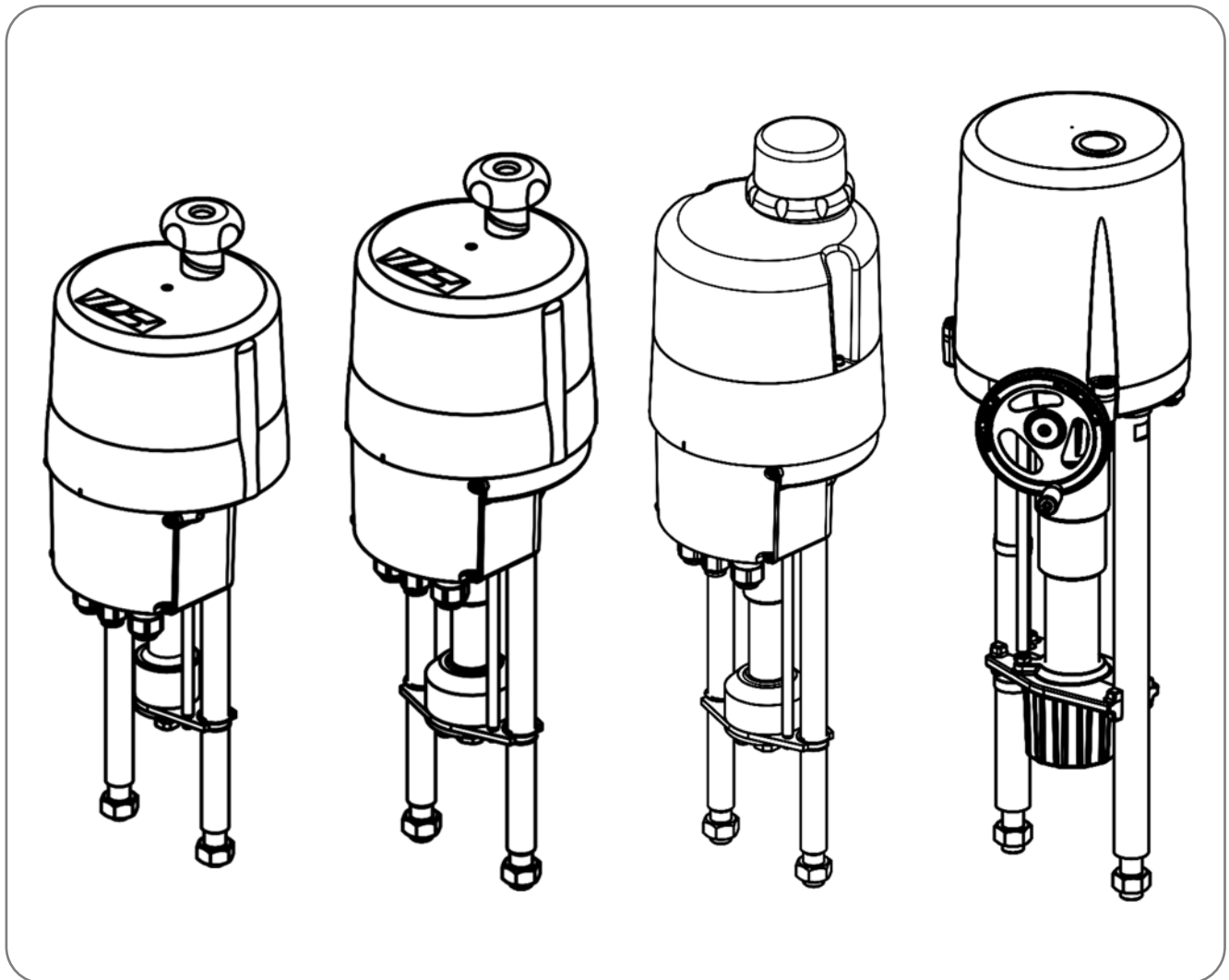

Contents

Contents	2
1. Symbols and safety	3
2. Usage as per specification	4
3. Storage	4
4. Operating conditions	4
4.1 Installation position	5
5. Function	5
6. Manual operation	6
7. Valve mounting	7
7.1 PS-AMS PSL202-214	7
7.2 PS-AMS PSL320-325	9
7.3 Force/Stroke-Dependent Limit Switch Cut-Off	10
8. Cover removal	11
9. Electric supply	11
9.1 Safety	11
9.2 Wiring diagram	12
9.3 Mains supply	13
9.3.1 Mains supply 1-phase AC/DC	13
9.3.2 Mains supply 3-phase AC (optional)	13
9.3.2 Mains supply PS-AMS PSL320/325 with integrated local control station PSC.2	14
9.4 Interfaces	15
9.4.1 Communication interface	15
9.4.2 Input terminals	15
9.4.2.1 Galvanically isolated set-value	15
9.4.2.2 Sensor feedback for process controller (optional)	16
9.4.2.3 Galvanically isolated binary input	16
9.4.2.4 Fail-safe port for binary input (optional)	16
9.4.3 Output terminals	16
9.4.3.1 Active position feedback	16
9.4.3.2 Additional signal switches (optional)	17
9.4.3.3 Voltage feed to process sensor (optional)	17
9.4.3.4 Fault indicating relay	17
9.4.3.5 Fieldbus interface (optional)	17
9.5 Accessories	17
9.5.1 Heating resistor (optional)	17
9.5.2 Adjusting additional signal switches (optional)	18
10. Status display / Calibration elements	19
11. Closing the cover	19
12. Operation	19
12.1 Cut-off in end positions	20
12.1.1 Cut-off by force/torque	20
12.1.2 Cut-off by position automatically	20
12.1.3 Cut-off by position	20
13. Calibration	20
13.1 Auto-calibration	21
13.2 Manual calibration	21
14. Status messages	22
14.1 Fault indicator relay	22
14.2 Tracing faults chart	22
15. Maintenance	22
16. Disposal	22
17. Safety on transportation	22
18. Accessories	23
19. Tracing faults chart	24
20. EC declaration of conformity	26

1. Symbols and safety

General dangers of non-compliance with safety regulations

PS-AMS PSL actuators are built at state-of the art technology and are safe to operate. Despite of this, the actuators may be hazardous if operated by personnel that has not been sufficiently trained or at least instructed, and if the actuators are handled improperly, or not used as per specification.

This may

- cause danger to life and limb of the user or a third party,
- damage the actuator and other property belonging to the owner,
- reduce safety and function of the actuator.

To prevent such problems, please ensure that these operating instructions and the chapter on "Safety" in particular have been read and understood by all personnel involved in the installation, calibration, operation, maintenance and repair of the actuators.

Basic safety notes

- The actuators may only be operated by skilled and authorized operating personnel.
- Make sure to follow all security advices mentioned in these operating instructions, any national rules for accident prevention, as well as the owner's instructions for work, operation and safety.
- The isolating procedures specified in these operating instructions must be followed for all work pertaining to the installation, calibration, operation, change of operating conditions and modes, maintenance, inspection, repair and installation of accessories.
- Before opening the actuator cover, ensure that main supply is isolated and prevented from unintended re-connection.
- Areas that can be under voltage have to be isolated before working on them.
- Ensure that the actuators are always operated in faultless condition. Any damage or faults, and changes in the operational characteristics that may affect safety, must be reported at once.

Danger signs

The following danger signs are used in these operating instructions:



Caution! There is a general risk of damage related to health and/or properties.



Danger! Electrical voltages are present that may lead to death. Life threatening risks may occur due to electrical voltages!



Danger! This sign warns of hazards posing a risk to health. Ignoring these instructions can lead to injuries.



Attention! Observe precautions for handling. Electrostatic sensitive devices.

Other notes

- The motor surface temperature may rise when maintaining, inspecting and repairing the actuator immediately after the operation. There is a danger of burning the skin!
- Always consult the relevant operating instructions when mounting PS accessories or operating the actuator with PS accessories.
- Connections for signal in- and output are double isolated from circuits that can be under dangerous voltage.

2. Usage as per specification

- PS-AMS PSL linear actuators are exclusively designed to be used as electric valve actuators. They are meant to be mounted on valves in order to run their motors.
- Any other use is considered to be non-compliant and the manufacturer cannot be held liable for any damage resulting from it.
- The actuators can only be used within the limits laid out in the data sheets, catalogues and other documents. Otherwise, the manufacturer cannot be held liable for any resulting damage.
- Usage as per specification includes the observance of the operating, service and maintenance conditions laid down by the manufacturer.
- Not to be regarded as usage as per specification are mounting and adjusting the actuator as well as servicing. Special precautions have to be taken while doing this!
- The actuators may only be used, serviced and repaired by personnel that is familiar with them and informed about potential hazards. The specific regulations for the prevention of accidents have to be observed.
- Damages caused by unauthorized modifications carried out on the actuators are excluded from the manufacturer's liability.
- Supply voltage may only be switched on after the proper closure of the main cover or terminal box.

3. Storage

For appropriate storage, the following instructions have to be met:

- Only store the actuators in ventilated, dry rooms.
- Store the actuators on shelves, wooden boards, etc., to protect them from floor moisture.
- Cover the actuators with plastic foil to protect them from dust and dirt.
- Protect the actuators against mechanical damage.

4. Operating conditions

- PS-AMS PSL actuators may be operated at ambient temperatures from -4°F to 140°F.
- Operating modes correspond to DIN EN 60034-1: S2 for short cycle and S4 for standard operation (for actuator specific data see the actuator specific data sheets).
- For protection against moisture and dust, the enclosure rating is IP65 or IP67 according to EN 60529.
- When installing the actuators, leave enough space to allow cover removal (Fig.1).

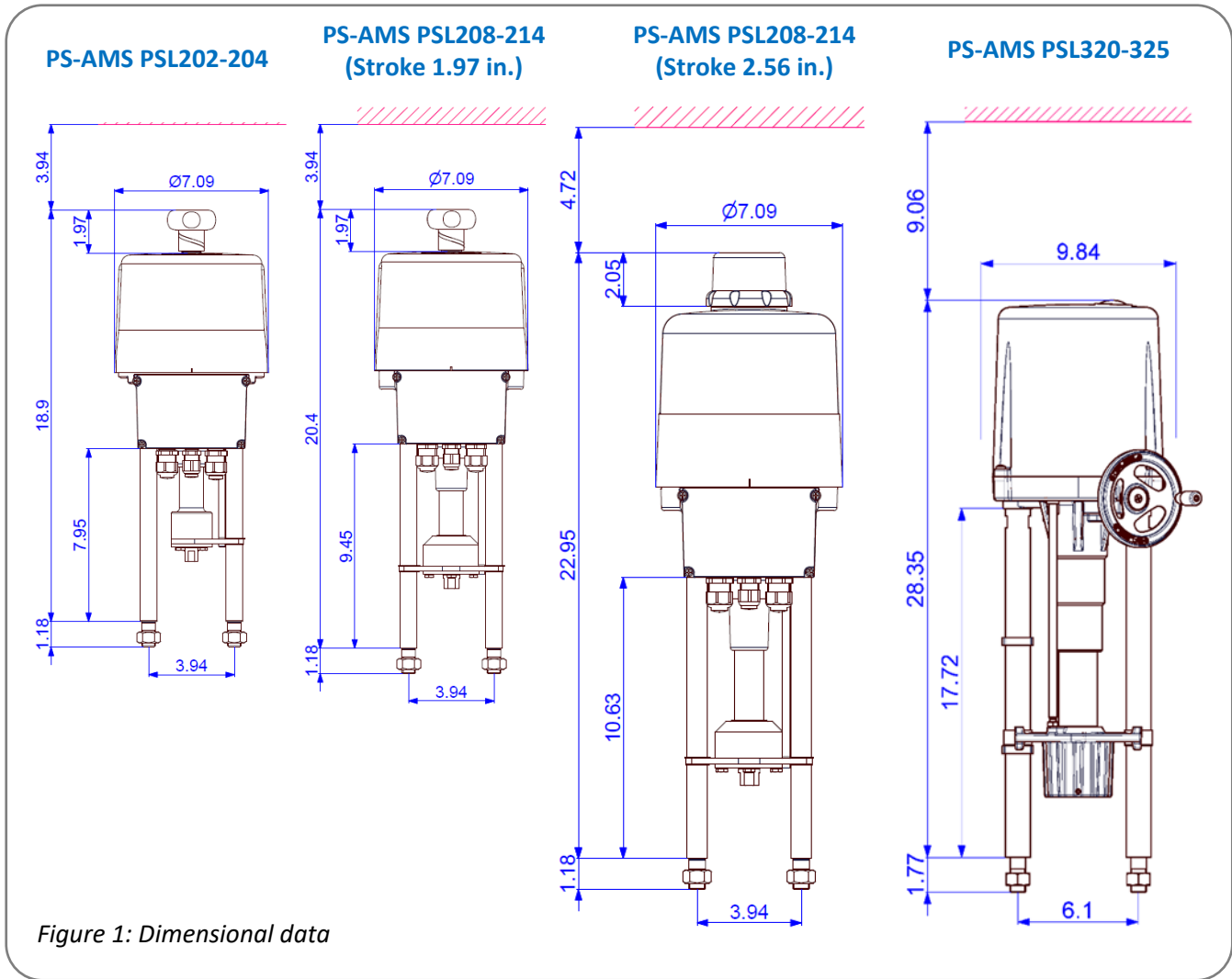

4.1 Installation position

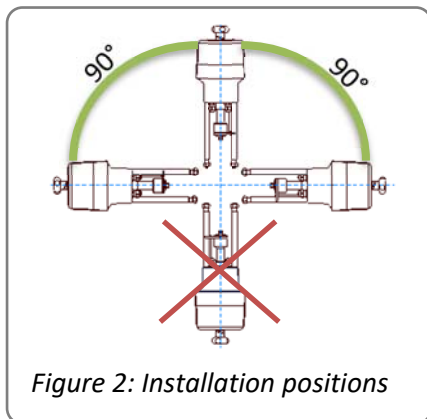

Outdoor usage:



When using the actuators in environments with high temperature fluctuations or high humidity, we recommend using a heating resistor as well as a higher enclosure rating (optional accessories).

5. Function

The PS-AMS PSL actuators are designed as electric valve actuators. The valve is mounted onto the actuator via pedestals. Depending on the type of valve used, mounting pedestals or a special valve mounting plate is required.

Mechanical power is created by a 24 volts DC-motor which is controlled from the electronics via pulse width modulation (PWM). The motor torque is transmitted via a multi-step spur gear to a trapezoidal thread spindle. The spindle itself converts the induced torque into an axial force via a spindle nut. The spindle nut's resulting linear vertical motion is self-locking and is transmitted via a coupling piece to the valve stem.

During power failure and adjustment work the actuators can be emergency-operated via the handwheel (see chapter 6/Manual operation), except when using the fail-safe unit PSCP.

6. Manual operation

The actuators are supplied with a loosely enclosed handwheel in order to operate the actuator in case of power loss or during installation work such as mounting onto a valve or setting the limit positions. Mount the handwheel according to *Figure 3*.

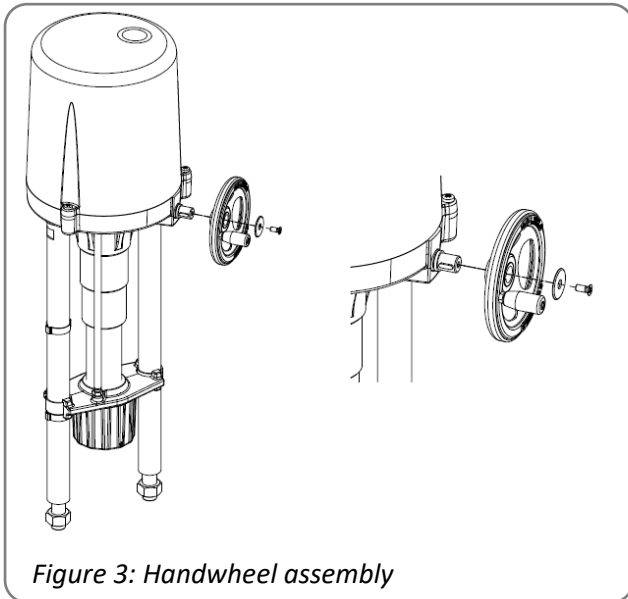

Figure 3: Handwheel assembly



Do not exceed the adjusted electrical stroke limits by handwheel. The mechanical limits must be set accordingly. If these instructions are not observed, it may result in malfunction or damage to the actuator.



Operate the handwheel only manually. Do not replace it and do not operate it by using excessive force or a motor. If these instructions are not observed, it may result in malfunction or damage to the actuator.

- The handwheel is permanently engaged and turns during motor operation of the device series PS-AMS PSL202-214.
- The actuators PS-AMS PSL320-325 have a handwheel which has to be engaged for manual operation. The button on the cover has to be depressed to engage the handwheel.

PS-AMS PSL202-204

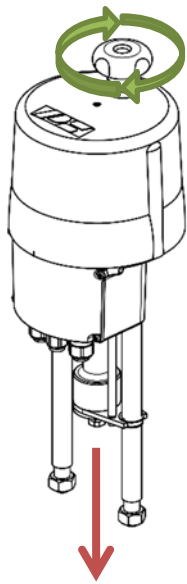

PS-AMS PSL208-214
(Stroke 1.97 in.)

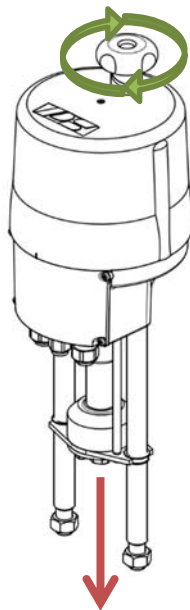

PS-AMS PSL208-214
(Stroke 2.56 in.)*

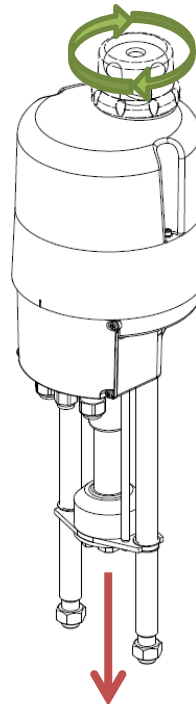

PS-AMS PSL320-325

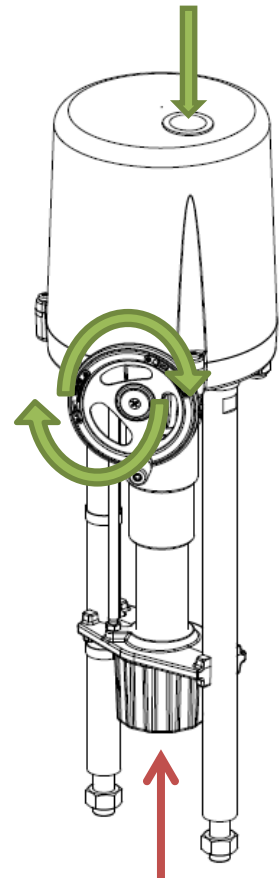

Figure 4: Manual operation

*PS-AMS PSL208-214 Stroke 65m: Please remove the handwheel cover

7. Valve mounting

7.1 PS-AMS PSL202-214

Note: The pictures below show the mounting of a PS-AMS PSL204. The steps are identical for all types.



When mounting the actuator onto the valve, use the handwheel and do not drive the actuator electrically. If these instructions are not observed, it may result in personal injury or damage to the actuator and/or valve.

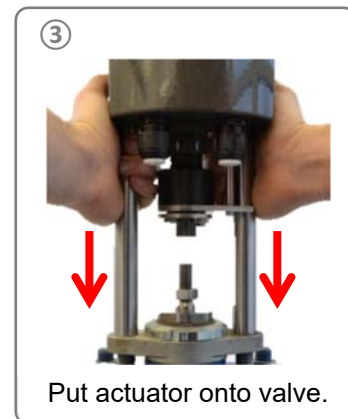
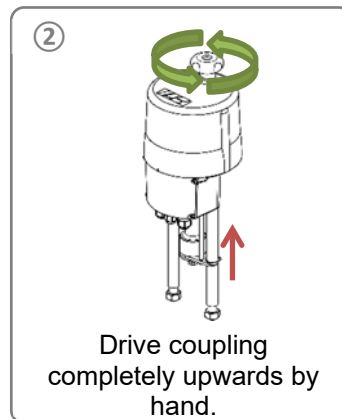
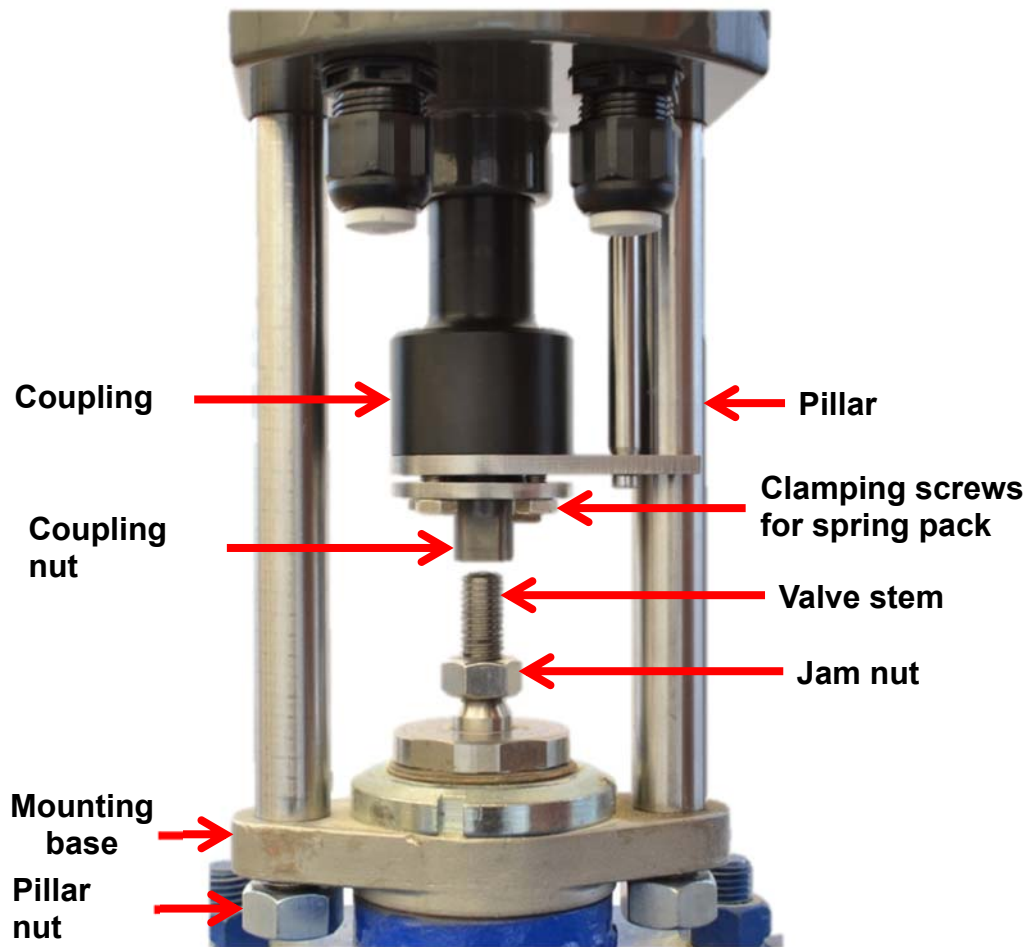

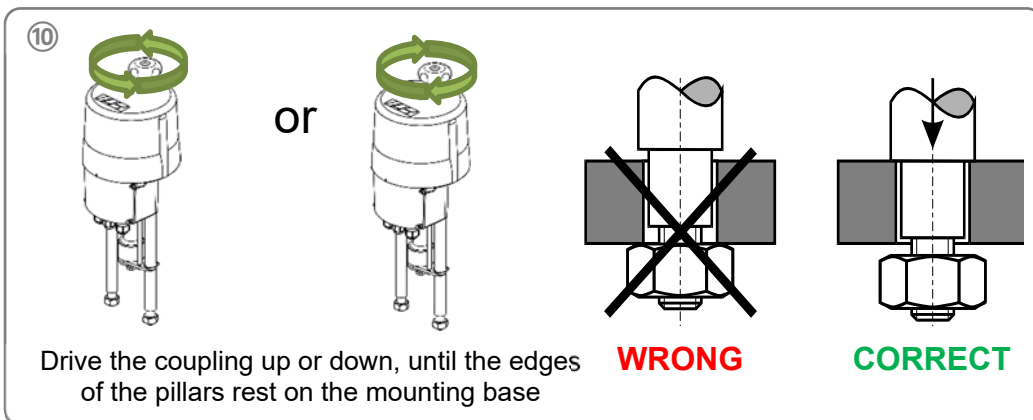
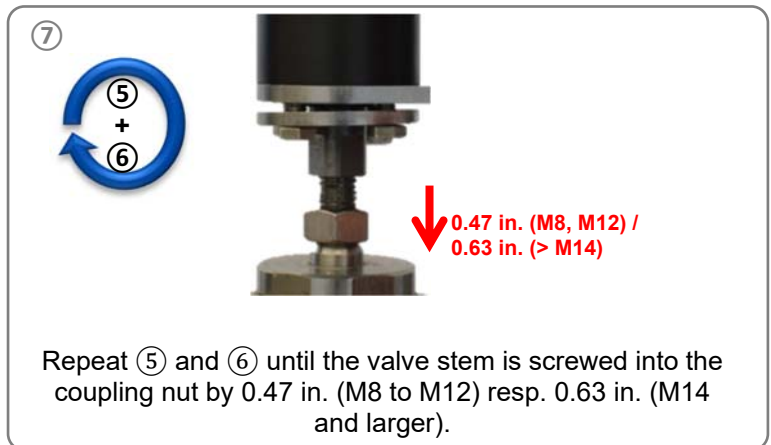
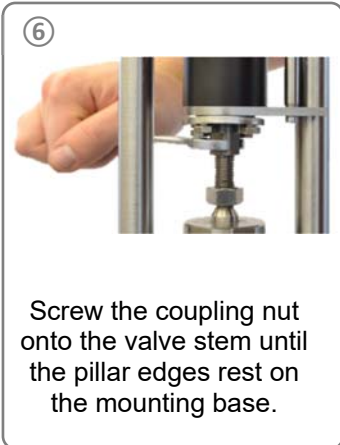
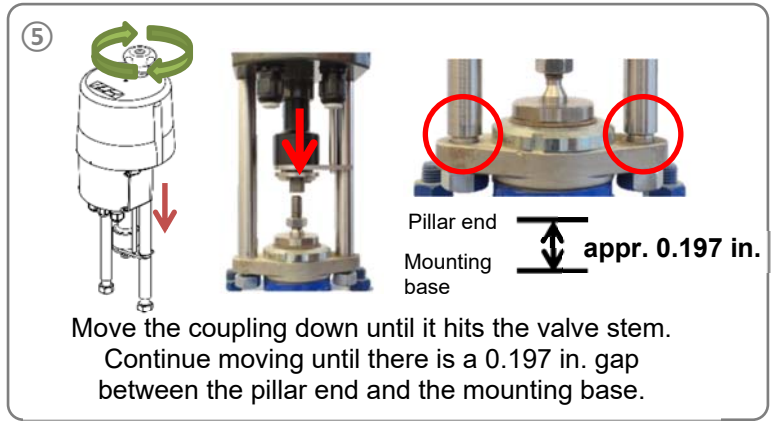
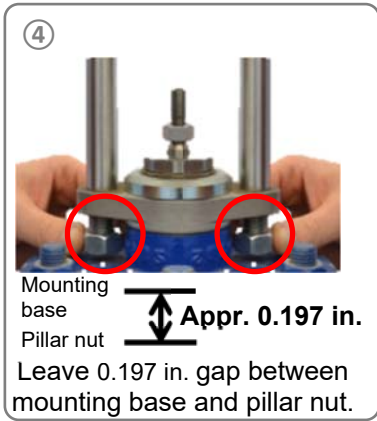

Before the fastening nuts are tightened, make sure that the pedestal ends are completely inserted into the bores of the valve mounting plate. If necessary, correct the position of the actuator by using the handwheel. If these instructions are not observed, it may result in personal injury or damage to the actuator and/or valve.

7.2 PS-AMS PSL320-325



When mounting an actuator onto a valve, never drive the actuator electrically but use the handwheel.

If these instructions are not observed, it may result in personal injury or damage to the actuator and/or valve.

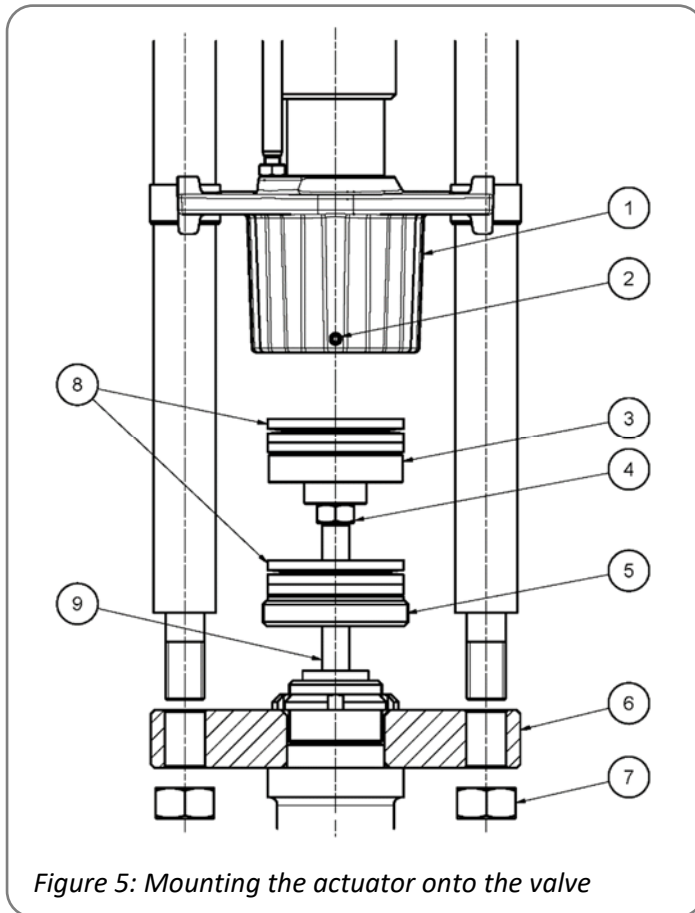

Figure 5: Mounting the actuator onto the valve

1	=	spindle nut
2	=	grub screw
3	=	coupling piece
4	=	counter nut
5	=	locking nut
6	=	mounting bracket
7	=	pillar nut
8	=	disc springs
9	=	valve stem

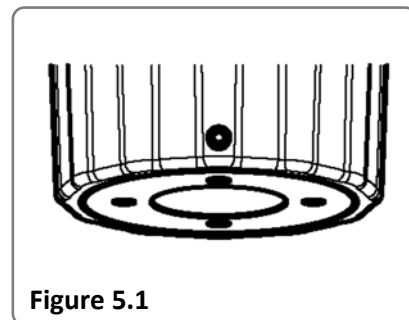

Figure 5.1

The valve must be suitably equipped to take the pillars. Please see the individual dimension sheets for the actuator dimensions. Observe the following steps when mounting the actuator:

- Unscrew the locking nut (item 5) from the spindle nut (item 1) and slide it over the valve stem (item 9).
- See if the bore of the coupling piece (item 3) fits the valve stem. If necessary, rebores and/or recut the thread.
- Slide or screw the coupling piece onto the valve stem and bore or pin to the valve stem. You may also secure the coupling piece by using a counter nut (item 4) (Lay the cup springs according to Figure 6 on page 10).
- Slide the pillars into the bore holes of the mounting bracket (item 6) and tighten with the pillar nuts (item 7).
- Extend the spindle nut by hand and move it completely over the disc springs and coupling piece, apply the locking nut and screw it in slightly, extend the spindle nut further and compress the disc springs until the locking nut can be tightened with the supplied face wrench to the stop, the locking nut is then flush with the lower edge of the spindle nut and does not protrude (Figure 5.1), if necessary compress the disc springs further by hand wheel.
- Tighten grub screw (pos. 2) with hexagon socket, locking nut is thus secured against loosening.



Before the fastening nuts are tightened, make sure that the pedestal ends are completely inserted into the bores of the valve mounting plate. If necessary, correct the position of the actuator using the handwheel. If these instructions are not observed, it may result in damage to the actuator and/or valve.

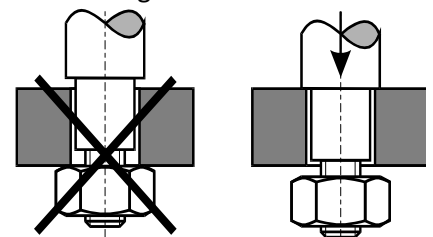

WRONG

CORRECT

7.3 Force/Stroke-Dependent Limit Switch Cut-Off

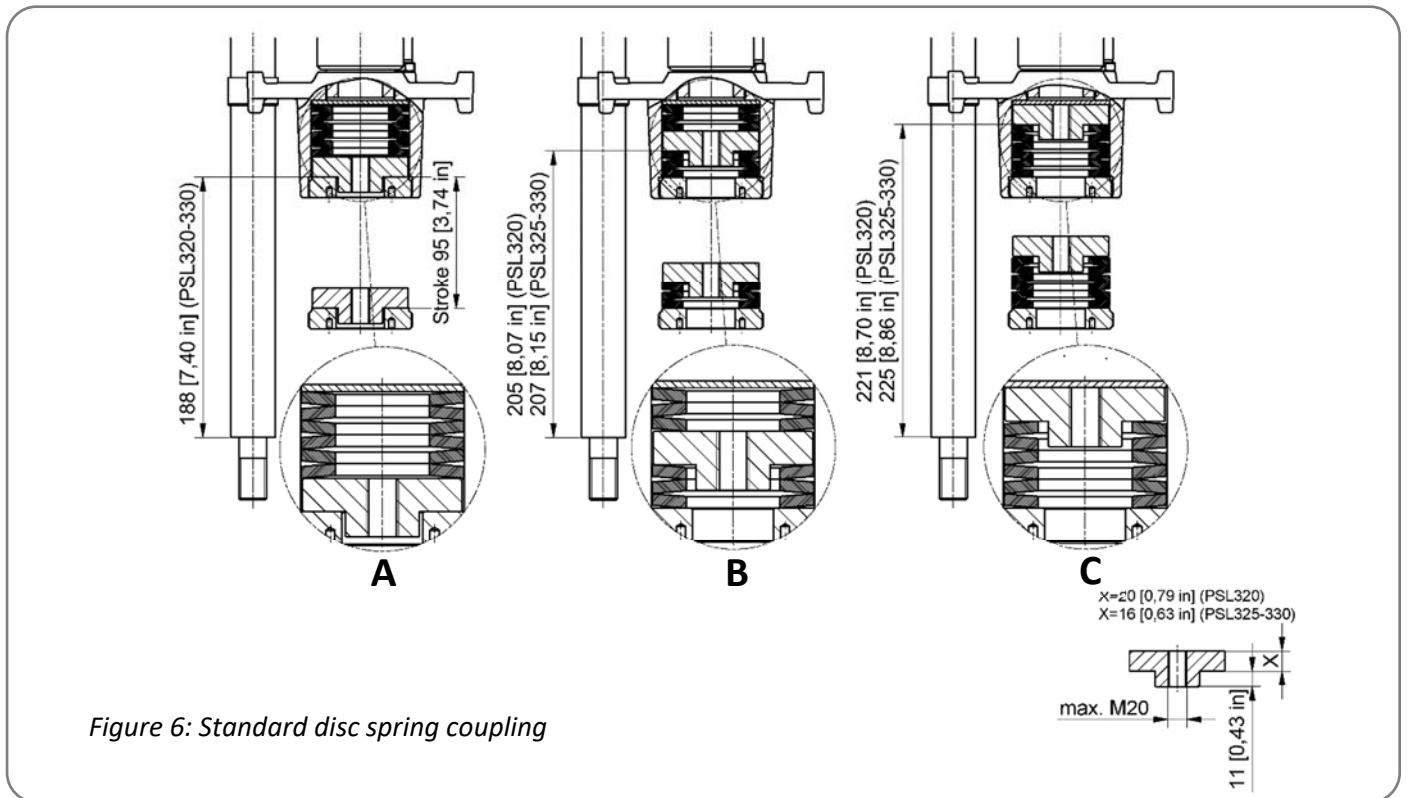

Figure 6: Standard disc spring coupling

The different methods of arranging the discs are dependent on the type of valve. Three different methods are possible:

- A: Arrangement for a through-valve with "Valve stem retracting" as direction of closing (Figure 6).
- B: Arrangement for a 3-way valve (Figure 6).
- C: Arrangement for a through valve with "Valve stem extending" as direction of closing (Figure 6).



3-way valves using the spring disc arrangement "B" require only half of the spring stroke designated in the spring pressure graph below!

Basic rule:

- For a through-valve, first set the CLOSED position force/stroke-dependent, then the OPEN position stroke-dependent.
- For a 3-way valve set both limit positions force/stroke-dependent.

8. Cover removal

Please observe the label on the cover of the actuator.



Attention! Observe precautions for handling.

- Ground the actuator.
- Before opening the cover, touch grounded housing parts.

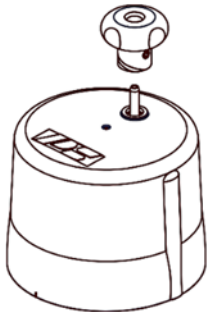

PS-AMS PSL202 – PS-AMS PSL210 (IP65)

Remove the handwheel by loosening it.
Pull the cover upwards.



For electrical connection the cover doesn't need to be removed.

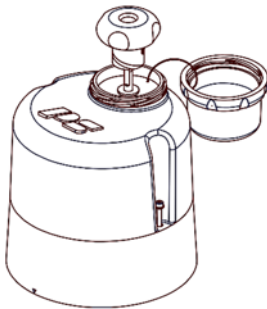

PS-AMS PSL214 and PS-AMS PSL202-210 IP67

Remove the handwheel by loosening the grub screw.
Remove the fastening screws of the actuator cover.
Pull the cover upwards.



For electrical connection the cover don't need to be removed.

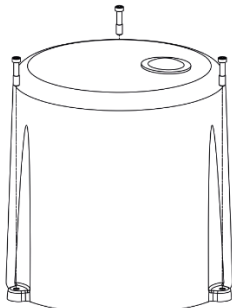

PS-AMS PSL320 – PS-AMS PSL325

Remove the fastening screws of the actuator cover.
Pull the cover upwards.

Figure 7: Cover removal

9. Electric supply

9.1 Safety



Electrical connection work may only be carried out by an authorised professional.

When performing electric work on this unit, the local accident prevention regulations must be followed.

Observe EN 60204-1 (VDE 0113 part 1) to ensure human safety, integrity of the assets as well as the proper functioning of the unit.

Electric supply lines must be dimensioned for the peak current of the unit and comply with IEC 227 and IEC 245. See relevant data sheet.

Yellow-and-green coded cords may only be used for connection to protective earth.

When leading wires through the conduit entries on the actuator, their minimum bending radius has to be considered.



The electric actuators PS-AMS PSL are not fitted with an internal electric isolator, hence a switching device or circuit breaker must be integrated in the facility. It should be installed close to the actuator and should be easy to access for the user. It is important to mark the circuit breaker as this actuator's isolator.



Electric installation as well as over-current and overvoltage protection devices must conform to the standard DIN IEC 60364-4-41, protective class I resp. protection class 3 (24VAC/24VDC) and also to the standard DIN IEC 60364-4-44 according to the applied overvoltage category of the actuator.

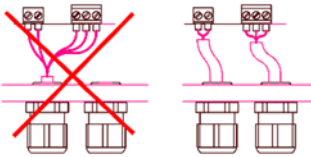

Please protect all of the power supply and control cables in front of the terminals mechanically by using suitable measures against unintentional loosening. Never install the power supply and the control cables together in one line but instead please always use two different lines.



PE earth connection has to be connected to gear casing at  !

Ensure that all connecting cables are stripped to the correct length so that they are protected against electric shock.

9.2 Wiring diagram

Depending on the actuator size, electric terminals are either provided in a terminal box at the actuator or under the cover. After wiring is completed, close the cover of the terminal box and the actuator properly and tighten the conduit entries to ensure enclosure as per the specified rating. The wiring diagram might differ for special actuator versions.

																							1-Phasen Wechselspannung / DC 1-Phase AC / DC				3-Phasen 3-Phase AC				
1	2	3	4	5	6	7	8	9	10	11	12	13	14	15	16	17	18	19	20	21	22	23	PE	RJ-45 TTL		Taster Button	L1	L2	L3	PE	
↑	↑	↑	↓	↓	↓	↕	↕	↑	↑	↑	↑	↑	↓	↑	↑	↑	↕	↕	↕	↕	↑	↑	PE	(Option)			↑	↑	↑	PE	
+ 0(2) - 10 V	+ 0(4) - 20 mA	GND	+ 0(2) - 10 V	+ 0(4) - 20 mA	GND	24 VDC	max. Last / max. Load 100 mA bei / at 24 VDC	L+ AUFL/ OPEN	N/-	L+ ZUL/ CLOSE	L+ (24V AC/DC - 230VAC)	N/- (24V AC/DC - 230VAC)	21 - 40 VDC / 100 mA	+ 0(2) - 10 V	+ 0(4) - 20 mA	GND	(Option)	(Option)	(Option)	(Option)	(Option)	L+ (siehe Typenschild / see tag plate)	N/- (siehe Typenschild / see tag plate)	PE	(Option)			400 VAC	400 VAC	400 VAC	Schutzleiter / protective conductor
Sollwert-Eingang	Aktive Positions-rückmeldung		Störmeldung potentialfrei	Binäre Ansteuerung	Netz-ausfall-signal	Ver-sorgung	Istwert	Zu / Closed	Auf / Open	Wegschalter potentialfreier Kontakt	Versorgungsspannung	Feldbus-Anschluß	PC Kommunikation	Inbetriebnahme	Versorgungsspannung						Power supply voltage	Fieldbus interface	PC communication	Commissioning							Schaltnetzteil
Galvanisch getrennt / Galvanically isolated 1 kV												Process-Sensor								8013770 - S-217_G											

Figure 8: Electric terminals

9.3 Mains supply

9.3.1 Mains supply 1-phase AC/DC



Electrical connection work may only be carried out by an authorised professional.

Isolate the power supply. **Safeguard the line against unauthorized and unintended restarting.**

Open the terminal box.

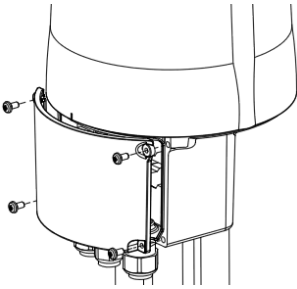

The terminal box provides terminals to accommodate rigid and flexible cables of wire widths of 0.00022 in.² to 0,0039 in.² as well as a PE screw on the housing.

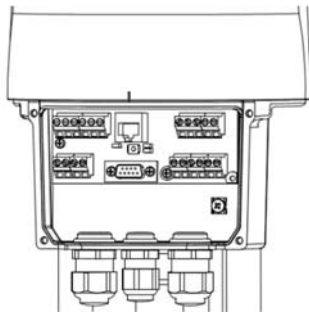

Caution: Please observe the supply voltage and the maximum power consumption of the actuator as indicated on the actuator's tag plate!

Connect supply and control lines to terminals (as indicated in the wiring diagram).

9.3.2 Mains supply 3-phase AC (optional)

Isolate the power supply.

Safeguard the line against unauthorized and unintended restarting.

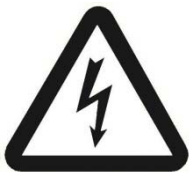

To connect supply, connect directly to internal mains adapter.

Connect supply and control lines to terminals (as indicated in the wiring diagram for 3-phase AC).

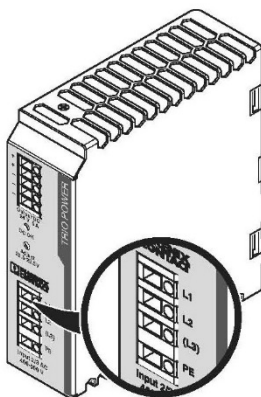

9.3.2 Mains supply PS-AMS PSL320/325 with integrated local control station PSC.2



Isolate the power supply.

Safeguard the line against unauthorized and unintended restarting.

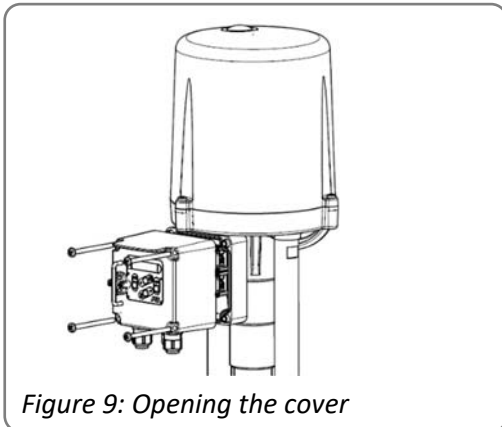

Figure 9: Opening the cover

Open the cover of the local control station PSC.2.

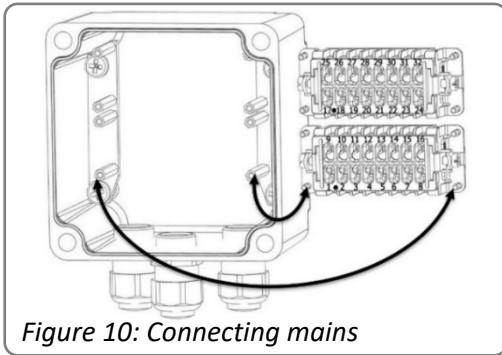

Figure 10: Connecting mains

Feed the cable through the conduit entries in the inner room of the cover. For wiring, loosen the four holding screws of the respective terminal box of the frame. The wiring must be made on the back side of the box.

The terminal box provides terminals to accommodate rigid and flexible cables of wire widths of 0.00022 in.² to 0.0039 in.² as well as a PE screw on the housing. Connect supply and control lines to terminals.

		Pin-Number							
Set Value Input	+ 0(2) - 10 V	→	1	9	→	21 - 40 VDC / 100 mA	Supply	Process Sensor (Option)	
	+ 0(4) - 20 mA	→	2	10	←	+ 0(2) - 10 V	Actual Value		
	GND	→	3	11	←	+ 0(4) - 20 mA			
Active Feedback	+ 0(2) - 10 V	←	4	12	←	GND			
	+ 0(4) - 20 mA	←	5	13		(reserved)			
	GND	←	6	14		(reserved)			
	(reserved)		7	15		(reserved)			
	(reserved)		8	16		(reserved)			

		Pin-Number							
Binary Input Signals	24V AC/DC - 230 VAC	L/+ OPEN	→	17	25	←	L/+ (24V AC/DC)	Fail Safe Signal (Option)	
		N/-	→	18	26	←	N/- (24V AC/DC)		
		L/+ CLOSE	→	19	27	↔	(Option)		
Monitor Relay potential-free	max. load 100 mA at 24 VDC		↔	20	28	↔	(Option)	Close	Position Switch potential-free contact
			↔	21	29	↔	(Option)	Open NC	
Position Switch potential-free contact	Closed NO	(Option)	↔	22	30	↔	(Option)	Open	Power Supply Voltage
	Open NO	(Option)	↔	23	31	←	N/- (see name plate)		
	PE	→	⊕	32	←	L/+ (see name plate)			

S-223_224_E

Figure 11: Wiring diagram with local control PSC.2 or terminal box for 1-phase AC/DC

Connect supply and control lines to terminals.

		Pin-Number							
Set Value Input	+ 0(2) - 10 V	→	1	9	→	21 - 40 VDC / 100 mA	Supply	Actual Value	Process Sensor
	+ 0(4) - 20 mA	→	2	10	←	+ 0(2) - 10 V			
	GND	→	3	11	←	+ 0(4) - 20 mA			
Active Feedback	+ 0(2) - 10 V	←	4	12	←	GND			
	+ 0(4) - 20 mA	←	5	13		(reserved)			
	GND	←	6	14		(reserved)			
	(reserved)		7	15		(reserved)			
	(reserved)		8	16		(reserved)			

		Pin-Number							
Binary Input Signals	24V AC/DC - 230 VAC	L/+ OPEN	→	17	25	←	L/+ (24V AC/DC)	Fail Safe Signal	Position Switch potential-free contact
		N/-	→	18	26	←	N/- (24V AC/DC)		
		L/+ CLOSE	→	19	27	↔	(Option) COM		
Fault Indicate on Relay potential-free	max. load 100 mA at 24 VDC		↔	20	28	↔	(Option) NC/NO*	Position Switch potential-free contact	
			↔	21	29	↔	(Option) COM		
Power Supply Voltage	L2 400 VAC	→	22	30	↔	(Option) NC/NO*	Position Switch potential-free contact		
	L3 400 VAC	→	23	31	←	N			
			24	32	←	L1 400 VAC	Power Supply Voltage		

PE

S-310_B

*) Position-Switch NC / NO: swap at terminal X6 to change

Figure 12: Wiring diagram with local control PSC.2 or terminal box for 3-phase AC

9.4 Interfaces

The actuator PS-AMS PSL has several interfaces inside the terminal box which can be configured by the parameterizing software PSCS or by the local control station PSC.2 (see relevant manuals).

9.4.1 Communication interface

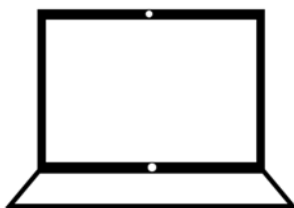

For communication and parameterization with a PC or a hand-held device, connect the communication cable to the RJ45-connector. Actuator parameters can be set using the software PSCS (see relevant manuals).

9.4.2 Input terminals

9.4.2.1 Galvanically isolated set-value

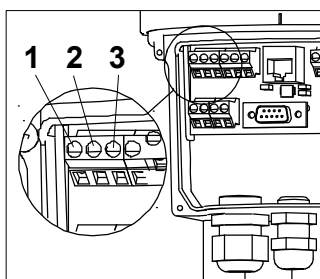

Terminals 1 to 3 are used to receive a parameterisable modulating set-value for control operation within the range of 0-20 mA or 0-10 V. Split range is also possible.

9.4.2.2 Sensor feedback for process controller (optional)

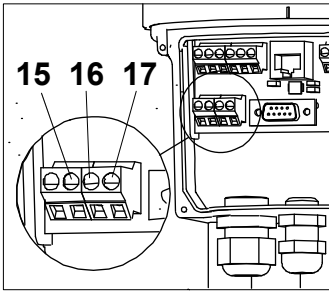

Terminals 15 to 17 are used to receive a process sensor's feedback to the - optional - process controller, in the parameterisable range of 0-20 mA or 0-10 V.



Caution!

The following binary inputs (9.4.2.3 und 9.4.2.4) have priority over the modulating set-value. If the actuator is parameterised for modulating service, these set-value settings are disregarded in the case a binary signal is applied. Only after disconnection of the binary signal the actuator will reposition according to the set-value applied.

9.4.2.3 Galvanically isolated binary input

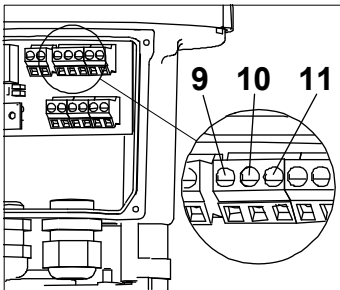

Terminals 9 to 11 are for binary open/close signals. Standard voltage level is 24 V, option is for 115/230 V; see wiring plan. The actuator is then driven in 3-point service.

9.4.2.4 Fail-safe port for binary input (optional)

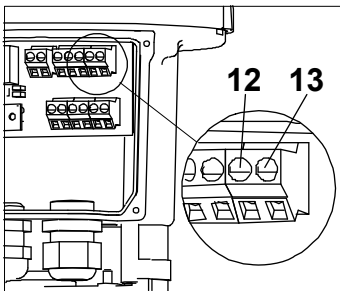

The fail-safe port (terminals 12 and 13) allows driving the actuator to a parameterized safety position by applying a voltage of 24 V. This input has priority over the galvanically isolated binary input.

9.4.3 Output terminals

9.4.3.1 Active position feedback

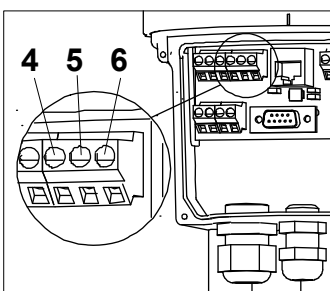

Terminals 4 to 6 are giving active position feedback, parameterisable within the range of 0-20 mA or 0-10 V.

9.4.3.2 Additional signal switches (optional)

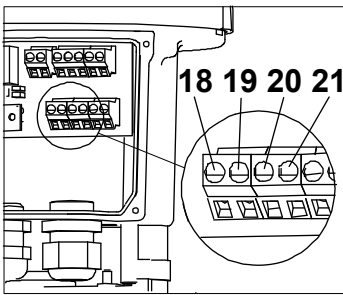

The activation points of the optionally available signal switches are freely adjustable via cams. Terminals 18/19 and 20/21 provide potential-free opening or closing contacts. The standard switches are rated to 230 VAC/10 A (6 A inductively). Special switches with gold plated contacts are available for low power (up to 100 mA and 30 V).

9.4.3.3 Voltage feed to process sensor (optional)

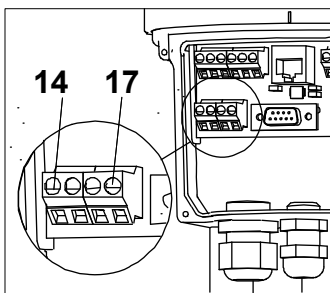

Terminals 14 and 17 provide an unregulated output voltage of 21 to 40 VAC at maximum 100 mA to feed an external process sensor.

9.4.3.4 Fault indicating relay

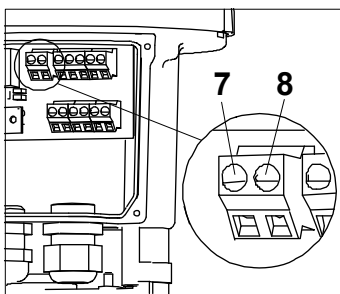

This potential-free normally-closed relay contact (terminals 7 and 8) allows displaying parameterisable fault indication to the control room. For configuration use the communication software PSCS.

9.4.3.5 Fieldbus interface (optional)

Optionally a fieldbus interface can be fitted to the PS-AMS actuator, with wiring to a terminal block or an external socket.

-> See special operating manual for PS-AMS fieldbus.

9.5 Accessories

9.5.1 Heating resistor (optional)

Actuators PS-AMS PSL can be fitted with a heating resistor. When using actuators in environments with high temperature fluctuations or high humidity, we suggest a heating resistor to be fitted to prevent the build-up of condensation within the enclosure.

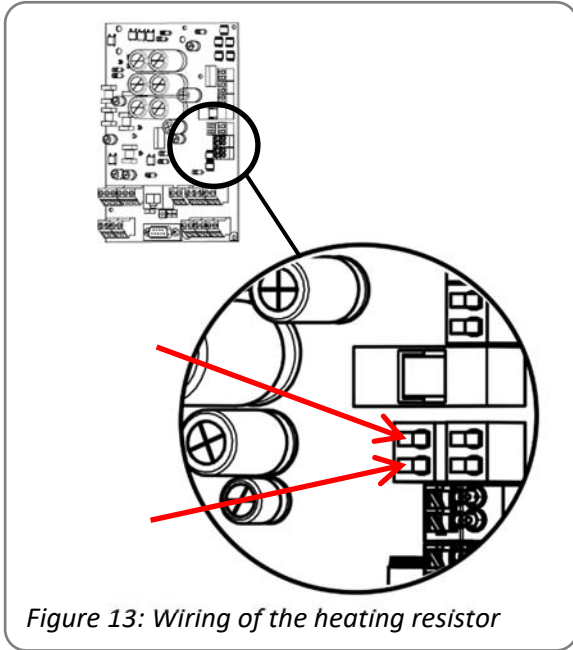

In actuators PS-AMS PSL the heating resistor is powered via the power supply of the actuator, so it does not have to be fed separately. For retro-fitting the heating resistor, wiring of the two cables has to be made to the terminals on the main board as per the figure on the left.

The heating resistor is available in two different versions (for 24 VAC/DC or 115-230 VAC). Please choose acc. to the voltage supply of the actuator.

Figure 13: Wiring of the heating resistor

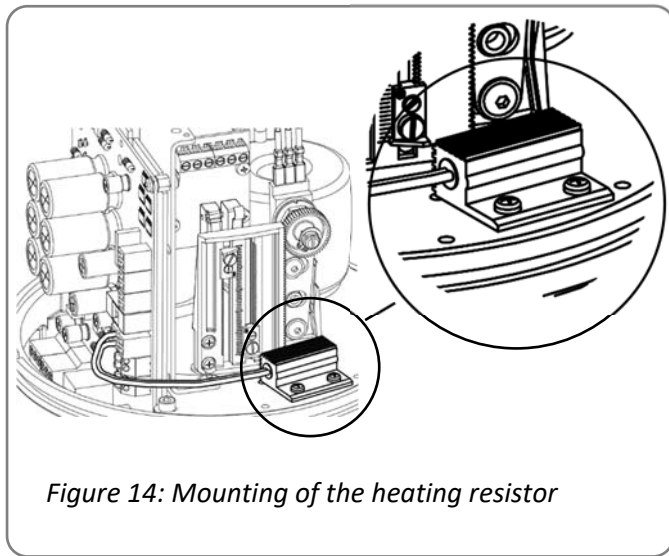

Mounting of the heating resistor has to be made to the indicated place on the base plate by using the screws provided. Route the cables in a way to prevent them from being squashed by the main cover, and from being touched by moving parts inside the actuator.



Route the cables in a way to prevent them from being squashed by the main cover, and from being touched by moving parts inside the actuator.

Figure 14: Mounting of the heating resistor

9.5.2 Adjusting additional signal switches (optional)

In PS-AMS PSL two switches for position feedback are available as factory-mounted option. They are potential-free changeover contacts. They are available with silver contacts (for currents between 10 mA and 5 A at maximum 230 V) or with gold-plated contacts (for currents between 0,1 mA and 30 mA at maximum 30 V). Connection goes to terminals 18/19 and 20/21 (see chapter 9.2).

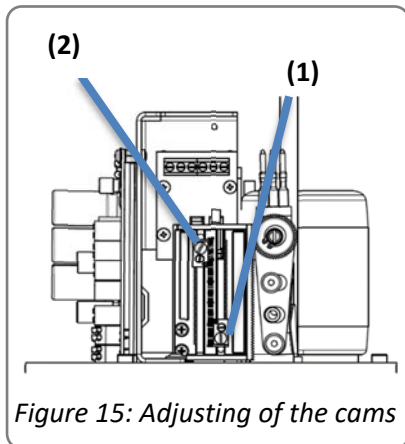

The cams for closing the switches are located on the switch plate, and are adjustable with a small screwdriver. Cam 1 is for retracting the spindle nut, while cam 2 is for extending the spindle nut out of the actuator.



The potentiometer must not be adjusted. Non-observance may cause damage to the actuator!

Figure 15: Adjusting of the cams

10. Status display / Calibration elements

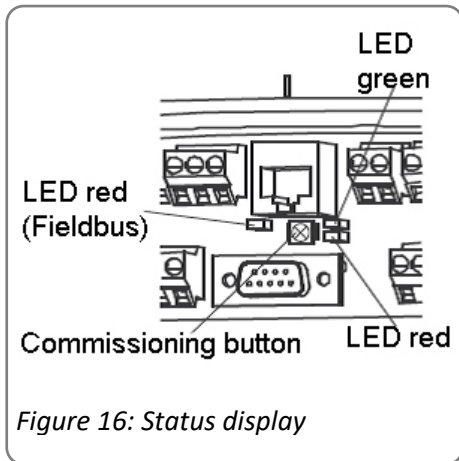

A red and a green LED on top of each other inside the terminal box indicate the status of the actuator.

Another single red LED (optional) signals the status of the optional fieldbus interface. -> See special operating manual for PS-AMS fieldbus.

The commissioning button for starting the auto-calibration run (to adjust the actuator to the valve) is located inside the terminal box, below the communication port.

11. Closing the cover

PS-AMS PSL201 – PS-AMS PSL210 (IP65)

Please observe the label on the cover of the actuator.

PS-AMS PSL202 – PS-AMS PSL210 (IP67) and PS-AMS PSL214

- Put the cover on the actuator and ensure that the two fixing screws are positioned over the corresponding threaded holes.
- Slightly tighten down the fixing screws with an Allen key. If the screws don't lock, move the cover slightly.
- Push the cover downwards and ensure that it slips over the sealing ring of the actuator.
- Tighten the screws.

PS-AMS PSL320 – PS-AMS PSL325

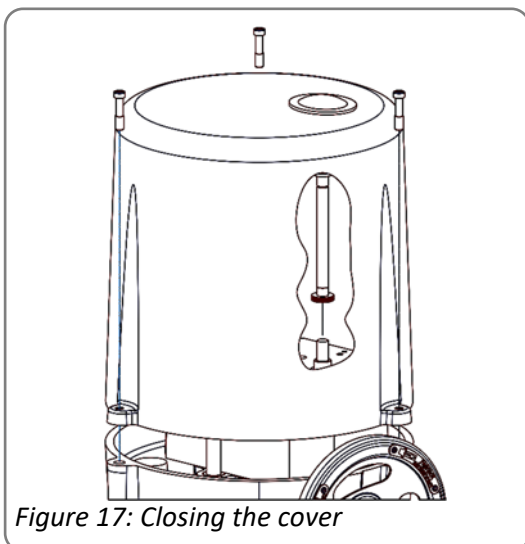

Figure 17: Closing the cover

- Check that the sealing ring on the periphery of the housing sits correctly in the groove.
- Put the cover on the actuator and ensure that the 3 fixing screws are positioned over the corresponding threaded holes and that the button is positioned over the release pin of the actuator housing.
- Tighten down the fixing screws with a corresponding screwdriver.

12. Operation

All internal parameters, like required motor torque, actual position, functional status, etc., are being permanently monitored during operation of the actuator PS-AMS PSL. This ensures that the actuator positions with optimum accuracy, and closes the valve always tightly. Deviations can be read out via communication software PSCS or via local control station PSC.2 (see respective instruction manuals), or can be displayed to the control room using the fault indication relay. This provides maximum safety of the process.

12.1 Cut-off in end positions

Cut-offs of the PS-AMS PSL actuators can be adjusted to meet the valve function in an optimum way by using the communication software PSCS (using a special interface cable, or optionally bluetooth connection). This will result in different behavior of the actuator. In case a position is surpassed or not reached, this can be read out via the fault indication relay or via the communication software PSCS.

12.1.1 Cut-off by force/torque

The actuator delivers the programmed maximum force/torque each time when driving to this end position. If the closing point inside the valve dislocates, e.g. when a seat gasket wears, then the actuator will drive further in its possible actuation range to try to reach the programmed force/torque.

12.1.2 Cut-off by position automatically

In normal operation, the actuator will stop at the position which was found at a mechanical stop in the valve or the actuator during auto-calibration. If the closing point inside the valve dislocates, the actuator will NOT follow this dislocation but it will always stop at the point initially found.

12.1.3 Cut-off by position

In normal operation, the actuator will stop at the point which was defined by manual calibration. This position is not depending on any mechanical stop inside the valve or actuator.

13. Calibration



**The electrical connection and commissioning with mains voltage applied may only be carried out by trained specialist personnel!
Do not touch any connection lines during commissioning!**

The actuator is shipped in the „not commissioned“ condition with the green LED flashing slowly. There will be **no** response to any input (control signal or open/close signal). To make the actuator operational, it has to be commissioned to a valve.

Depending on the type of cut-offs programmed (see 12.1) there are two ways to do calibration:

- **Auto-calibration** is done if at least one of the cut-offs is set to be “by force/torque” or “by position automatically”.
- **Manual calibration** has to be made in case both cut-offs are “by position”, either via software PSCS or via control box PSC.2.



Caution!
Electrical operation of the actuator is allowed only after mounting to a valve!



To avoid injuries due to live or rotating components, commissioning is allowed only while the main cover of the actuator is closed.

Attention! Observe precautions for handling. Electrostatic sensitive devices.

13.1 Auto-calibration

(Only available if at least one of the cut-offs is set to be “by force/torque” or “by position automatically”.)

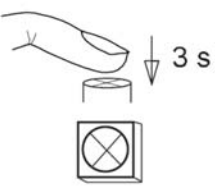
①  3 s

Press the commissioning button for 3 sec
(For position of commissioning button please see Figure 16).

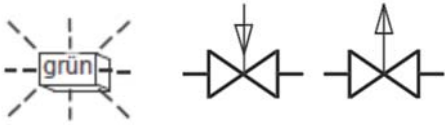
② 

Calibration in progress (Green LED is flashing, actuator drives in both positions).

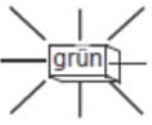
③ 

Green LED lights – Actuator successfully commissioned and ready to be used.

13.2 Manual calibration

① 

Connect your PSCS-USB cable with your PC and start the software.

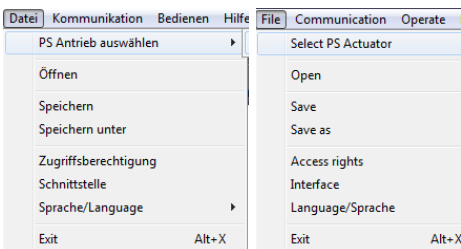
② 

Select actuator type and interface in the software.

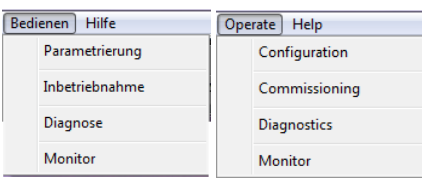
③ 

Select Operate -> Commissioning and confirm the dialog with OK.

④ When doing manual calibration, make sure that the correct control signal for the closed position, or the binary signal for driving to closed position is permanently applied, depending on the parameterised mode of operation.

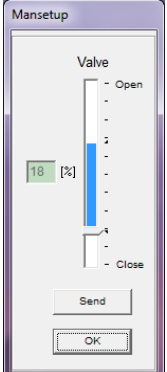
⑤ 

Adjust the closed position and check it with „send“; Save with OK.

⑥ 

Green LED lights – Actuator successfully commissioned and ready to be used.

Note

If the parameterized valve stroke, starting from the adjusted closed position, exceeds the possible actuator stroke, then the operating stroke will be reduced to the resulting maximum possible value.

14. Status messages

14.1 Fault indicator relay

Fault messages can be transmitted to the control room with a maximum load of 24 VDC/100 mA via a closing contact at terminals 7 and 8. The messages can be parameterized via software PSCS. The contact between terminals 7 and 8 is closed when there is no fault and the drive is supplied with power.

-> See relevant manuals PS-AMS PSCS

14.2 Tracing faults chart

See the table on page 25 for explanation of the blinking codes of the status-LEDs.

15. Maintenance

Under the conditions of use as per specification as lined out in the data sheet, the PS-AMS PSL actuators are free of maintenance. All gears are lubricated for their service life and do not require to be re-lubricated. Clean the actuators with a dry soft cloth and do not use any cleaning agent. Do not use any coarse or abrasive materials.



Caution !

During maintenance and repair the actuator must not be operated electrically.

16. Disposal



According to 2012/19/EU on waste electrical and electronic equipment (WEEE), the devices described here must not be disposed of via municipal waste disposal companies.

If you are unable or unwilling to arrange for disposal by a specialist company, you may return the equipment to the manufacturer, who will then ensure that the equipment is disposed of properly for a flat fee.

17. Safety on transportation

For transportation and storage all cable glands and connection flanges have to be closed to prevent ingress of moisture and dirt. A suitable method of packaging is required for transporting to avoid damage of coating and any external parts of the actuator.

18. Accessories

Various options are available in order to adapt the actuators to the various service conditions. A list of accessories for each actuator type is shown on the actuator data sheet.

Accessories/Options	Add. Signal Switches	2WE	Potential-free additional signal switches with silver contacts (0.1 A - 5 A switching current)
	Add. Signal Switches Gold	2WE Gold	Potential-free additional signal switches with gold contacts (0.1 mA - 100 mA switching current)
	Binary Inputs 115-230VAC*		Binary input voltage of 115-230 VAC for ON/OFF control
	Fail-Safe*	PSCP	Emergency power supply based on supercapacitors, safety position OPEN, CLOSED or free defined position
	Fieldbus Interface*		Digital transmission of nominal and actual value per mill or percent, report of monitoring and diagnostic data using Profibus DP (PSPDP) or CANOpen (PSCA) interfaces, additional interfaces available on request
	Local Control Station*	PSC.2	Illuminated display to show the actuator status and lockable selector to switch between modes: automatic, manual process ON/OFF, STOP and parameter menu. Control buttons for manual movement, menu operation and adjustment of parameters, display of diagnostic information
	Remote Local Control Station		Mounting separately from the actuator (incl. 10 m connection cable)
	Data Cable	PSCS-USB	USB data cable enables the communication between the actuator and a PC by using the software PSCS
	Fail-Safe Port*	FSP	Signal port to drive to a "safety position", selectable fail-safe position, standard 24 V
	IP67		Increased enclosure rating IP67
	Heating Resistor	HR	Heating resistor to prevent condensation

*not retrofittable

19. Tracing faults chart

Red LED			Green LED							
Glowing permanently	Flashing quickly	Flashing slowly	Off	Glowing permanently	Flashing quickly	Flashing slowly	Off			
			x				x	Status	Probable reasons	Possible remedy
			x					Actuator does not respond, both LEDs are off	1) No supply voltage applied 2) The applied voltage does not match the actuator voltage on the tag plate	1) Check mains supply 2) Apply correct supply voltage
			x	x				Actuator does not drive the full stroke	1) Actuator not correctly commissioned 2) Too small stroke programmed (in mode "one position-dependent cut-off")	1) Repeat calibration 2) Check valve stroke parameters -> see instructions PS-AMS PSCS
			x	x				Actuator does not close the valve properly	1) Actuator not correctly commissioned 2) by closing force/ torque too low	1) Repeat calibration 2) Check actuator selection
			x	x				Actuator is in normal operating condition, but does not respond to set-value changes	1) Fixed digital set-value is activated 2) Actuator is configured to work with process controller	1) Check set-value parameters -> see instructions PS-AMS PSCS 2) Connect process sensor
			x	x				Actuator position does not correspond to set-value input	A non-linear valve curve has been parameterised	Verify parameterised characteristic -> see instructions PS-AMS PSCS
								Operating conditions	Probable reasons	Possible remedy
			x	x				Normal operating condition		
			x		x			Actuator in commissioning mode		Calibration mode will be left automatically after completion
			x			x		Actuator not calibrated		Depending on the type of cut-offs, the actuator has to be commissioned either automatically or manually
								Faults within the actuator's environment	Probable reasons	Possible remedy
		x		x				Too high torque has been encountered within the valve stroke	1) Actuator not correctly commissioned to the valve 2) Mechanical block within the stroke path 3) Improper selection of the actuator	1) Repeat calibration 2) Check valve and actuator for unobstructed running 3) Check actuator selection
		x			x			1) No proper process feedback (only in combination with PSIC) 2+3) Maximum control range exceeds (only in combination with PSIC)	1) Process feedback wrongly or not at all connected 2) Process feedback outside od adjusted range 3) No process sensor signal available	1) Apply the correct process feedback signal and check polarity 2) Ensure the correct process feedback range 3) Check the process sensor and its supply voltage

Red LED				Green LED						
Glowing permanently	Flashing quickly	Flashing slowly	Off	Glowing permanently	Flashing quickly	Flashing slowly	Off			
								Faults within the actuator's environment	Probable reasons	Possible remedy
		x				x		Actuator drives into a preset position	1) Signal is applied to the binary fail-safe input 2) Supply voltage failure on actuators with optional PSCP	1) Disconnect the signal 2) Check supply voltage
		x					x	Set-value disconnected or outside the parameterized range	1) Set-value not connected 2) Wrong polarity of set-value 3) set-value signal outside parameter range, please check	1) Apply set-value 2) Check the set-value polarity 3) Check the set-value range
	x			x				Stored end position could not be reached	Loose or dirty valve seat	Check the valve seat
	x				x			Stored end position has been passed over	Valve seat worn or defective	Check the valve seat
	x					x		Actuator supply voltage too low	1) Improper wiring of the mains supply 2) Jitter in supply voltage 3) Too low supply voltage from PSEP (with optional PSEP)	1) Check mains wiring 2) Check supply voltage -> see datasheet 3) Contact PS service team
								Faults within the actuator	Probable reasons	Possible remedy
x				x				Actuator has reached lifetime limit	Wear and/ or running time	Contact PS service team
x					x			Faulty electronics or invalid parameters	1) Supply voltage interrupted during calibration 2) Defective electronic component	1) Reload parameters (-> see manual PS-AMS PSCS), then repeat calibration 2) Contact PS service team
x						x		Critical or maximum temperature reached	1) Too high numbers of starts 2) Ambient temperature too high	1) Check application and its adjustment 2) Check ambient temperature and try to reduce it -> see relevant data sheet
x							x	Mechanical fault in the actuator	Defective mechanical part	Contact PS service team

20. EC declaration of conformity

Declaration of Incorporation of Part Completed Machinery and EC Declaration of Conformity in compliance with the Directives on EMC and Low Voltage

We,

**PS Automation GmbH
Philipp-Krämer-Ring 13
D-67098 Bad Dürkheim**

Declare under our sole responsibility that we manufacture electric actuator series

**PSR-E...; PSQx03...; PSQ-E...; PSQ-AMS...; PSL-Mod.4...;
PSL-AMS...; PSF...; PSF-M...; PSF-Q...; PSF-Q-M...**

according to the requirements of the

EC Directive 2006/42/EC

as part completed machinery. These actuators are designed to be installed on industrial valves. It is prohibited to take the actuator into service until it has been ensured that the complete machine conforms to the applicable machinery directives. The technical documentation described in Annex VII, part B has been prepared.

The above actuators further comply with the requirements of the following directives.

2014/30/EU	Electromagnetic Compatibility (EMC)
2014/35/EU	Low Voltage (LVD)
2011/65/EU + 2015/863/EU	Restriction of Hazardous Substances (RoHS)

furthermore, the following harmonised standards have been applied:

EN 61000-6-2: 2005	Electromagnetic compatibility (EMC), Generic standards-Immunity for industrial environments
EN 61000-6-3: 2007	Electromagnetic compatibility (EMC), Generic standards-Emission standard for residential, commercial and light-industrial environments
EN 61010-1: 2020	Safety Requirements for Electrical Equipment for Measurement, Control and Laboratory use

Bad Dürkheim, 2022



Christian Schmidhuber
(General Manager)

CAUTION!

To ensure compliance of these actuators with the above directives, it is the responsibility of the specifier, purchaser, installer and user to observe the relevant specifications and limitations when taking the product into service. Details are available on request, and are mentioned in the Installation and Maintenance Instructions.

Our representatives:

Italy

PS Automazione S.r.l.
Via Pennella, 94
I-38057 Pergine Valsugana (TN)
Phone: <+39> 04 61-53 43 67
Fax: <+39> 04 61-50 48 62
E-mail: info@ps-automazione.it

India

PS Automation India Pvt. Ltd.
Srv. No. 25/1, Narhe Industrial Area,
A.P. Narhegaon, Tal. Haveli, Dist.
IND-411041 Pune
Phone: <+ 91> 20 25 47 39 66
Fax : <+ 91> 20 25 47 39 66
E-mail : sales@ps-automation.in
www.ps-automation.in

To find out more about all our sales partners and subsidiaries please scan the QR code below or visit our website:

<https://www.ps-automation.com/ps-automation/locations/?lang=ae>



PS Automation GmbH

Philipp-Krämer-Ring 13
D-67098 Bad Dürkheim
Phone: +49 (0) 6322 94980 – 0
E-mail: info@ps-automation.com
www.ps-automation.com

