

Operating Instructions

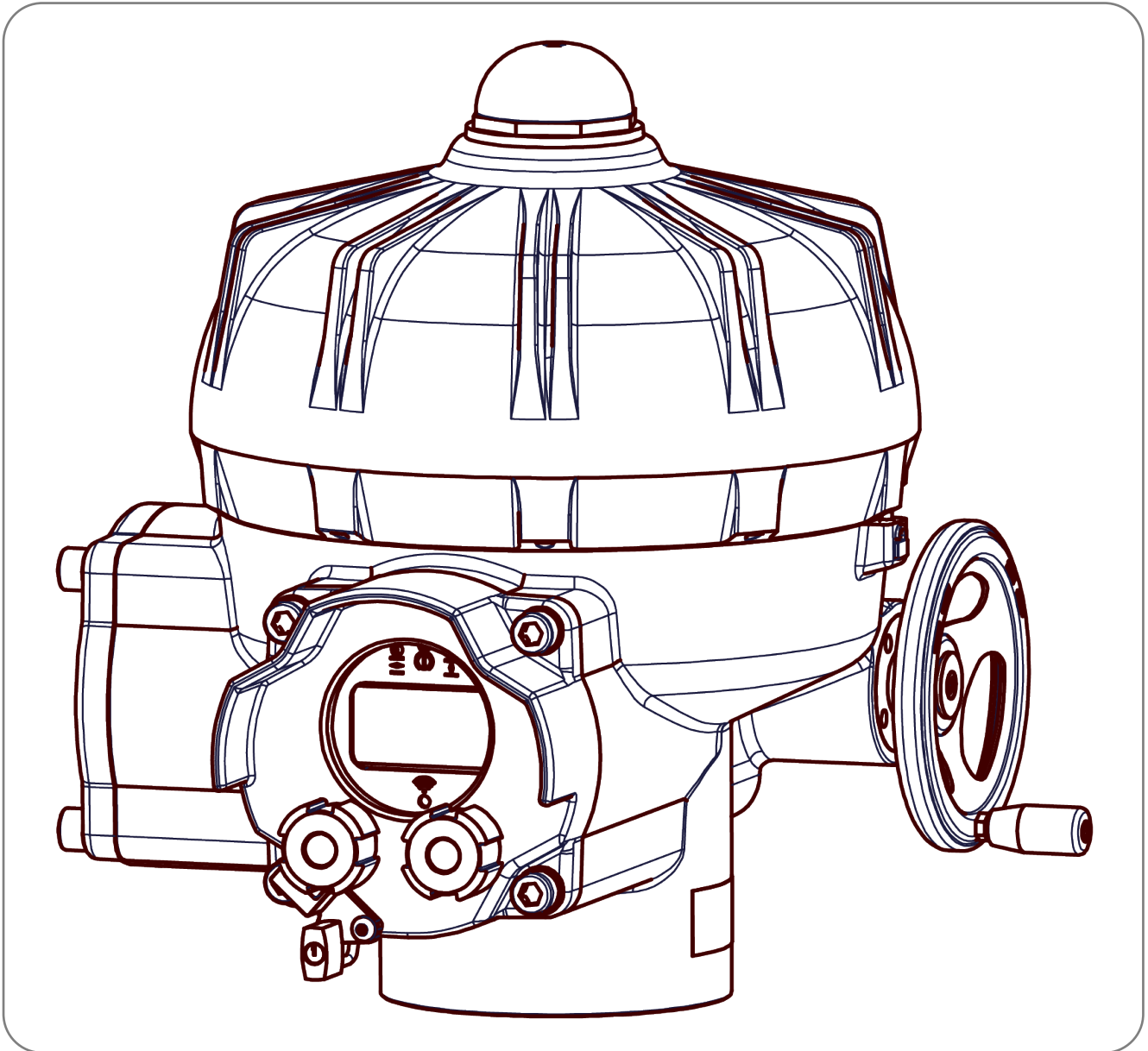

Subject to changes!

Contents

1. Product description	4
2. Applicable standards.....	4
3. Key figures.....	5
3.1 Type Key	6
4. Symbols and safety	6
5. Usage as per specification	7
5.1 Special conditions	8
6. Storage.....	8
7. Operating conditions and installation	8
8. Function	8
9. Mechanical assembly.....	9
9.1 Mounting the manual override.....	9
9.2 Installation positions.....	9
9.3 Flange connection / valve mounting.....	10
9.4 Setting the mechanical stop.....	11
10. Removing / closing the cover.....	12
11. Electric supply	13
11.1 Safety Note.....	13
11.2 Opening and closing the Ex-e room	14
11.3 Connection of cable glands Ex-e room.....	15
11.4 Opening the side EXd cover / PSC.3	15
11.5 Electrical connection PE	16
11.6 Connecting mains.....	16
11.6.1 Connection to terminals on the control board of the actuator	17
11.6.2 Connection diagram	17
11.6.2.1 Supply voltage 24 VDC	18
11.6.2.2 Supply voltage 24 VAC	18
11.6.2.3 Supply voltage 100-240 VAC 1~ (optional)	18
11.6.2.4 Supply voltage 200-440 VAC 3~ (optional)	18
11.7 Interfaces	18
11.7.1 Inputs with galvanic isolation.....	18
11.7.1.1 Analogue Set value A	18
11.7.1.2 Analogue Set value B.....	18
11.7.1.3 Binary input ports BA / BB / BC.....	19
11.7.1.4 Fieldbus interface (optional).....	19
11.7.2 Outputs with galvanic isolation.....	19
11.7.2.1 Analogue Position Feedback	19
11.7.2.2 Auxiliary voltage output (optional)	19
11.7.2.3 Potential-free position signal switches (optional)	19
11.7.2.4 Heating resistor	20
11.7.2.5 Potential-free signal relays with changeover contact 1-5 (optional).....	21
11.7.2.6 Communication Interface	21
12. Operation	22
12.1 Manual operation	22
12.2 Mechanical position indication	22
13. Status display / Commissioning elements	23
13.1 Actuator position / status / error messages	24
13.1.1 actuator disabled	24
13.1.2 Auto Mode	24
13.1.3 Manual mode	24
13.1.4 Function menu	25
13.1.5 Status display	26
13.2 PSC.3 local control panel (optional).....	26
13.3 Operation	26
13.3.1 Power regulation.....	26
13.3.2 Torque regulation	26
14. Commissioning.....	27
14.1 Automatic commissioning.....	27

14.2	Manual commissioning	27
15.	WLAN	27
16.	Diagnosis	27
17.	Maintenance and Servicing	27
17.1	Cleaning	28
17.2	Servicing	28
17.3	Spare parts	28
17.4	Service address	28
18.	Decommissioning and disposal	28
19.	Accessoires	29
20.	Declaration of incorporation of part completed machinery and EC declaration of conformity in compliance with the directives on EMC and low voltage	30

1. Product description

The quarter-turn actuator PS-AMS2 PSQ EX is an industrial, multifunctional smart modulating actuator with optional electrical fail-safe function using supercapacitors for the operation of industrial valves of various types across a wide range of applications. The actuator is designed for assembly with valves and their motor operation.

It is used as an electric valve actuator in hazardous areas of device category II 2G (Ex zone 1, Ex d e, device protection level Gb) or device category II 2D (Ex zone 21, device protection level Db) installed in a fixed position using mounting columns. A position indicator on the cover shows the current position of the actuator.

Parameterisation of the actuator is possible **in non-explosive areas** by cable or with mobile WiFi solutions suitable for the area. To protect against environmental influences, the cover and lower section are powder-coated. Conduit entries are available in the lower section of the housing for inserting the electrical cables.

The construction, as well as the interaction of the individual components and the housing regarding their suitability for use in hazardous areas, are tested by PS Automation GmbH and confirmed by the identification with the type label.

The actuator PS-AMS2 PSQ EX essentially consists of:

- the flange
- the plug-in coupling
- the housing section
- the mechanical section is located in the lower section of the housing (mounting plate)
- the Ex d terminal compartment is located in the upper section of the housing (underneath the cover hood)
- the Ex e/ t terminal compartment is located on the side of the actuator and consists of the lower part of the housing (mounting plate) with terminal compartment and the terminal compartment cover
- with conduit entries
- with connection panel for the electrical connections (electrical connection compartment)
- with Ex d motor control housing

2. Applicable standards

EN IEC 61000-6-1	Electromagnetic compatibility (EMC), Generic standards - Immunity standard for residential, commercial and light industrial environments
EN IEC 61000-6-4	Electromagnetic compatibility (EMC), Generic standards - Emission standard for industrial environments
EN IEC 61010-1	safety requirements for electrical equipment used in measurement, control, and laboratory environments.
EN 301 489-1 V2.1.1	Electromagnetic Compatibility (EMC) standard for radio equipment and services - part 1
EN 301 489-17 V3.1.1	Electromagnetic Compatibility (EMC) standard for radio equipment and services - part 17
EN 300 328 V2.1.1	Wideband transmission systems - Data transmission equipment operating in the 2,4 GHz band - Harmonised Standard for access to radio spectrum
EN IEC 60079-0	General requirements
EN IEC 60079-7	Equipment protection by increased safety “e”
EN IEC 60079-1	Equipment protection by flameproof enclosures “d”
EN IEC 60079-31	Explosive atmospheres - Part 31: Equipment dust ignition protection by enclosure “t”

3. Key figures

Device category	II 2G II 2D
EU Type Examination Certificate	TÜV-A 25ATEX0103 X
Ex marking	 Ex db eb IIC T6 Gb or Ex db eb IIC T4 Gb or Ex tb IIIC T80 °C Db or Ex tb IIIC T130 °C Db
Housing size	approx. 480 x 345 x 375mm (BxLxH) (Ex e / Ex t housing)
Force	Depending on variant
Operating time 90° in motor mode	60 - 200 Nm: 6-20s/90°
Angle of rotation	90°
Nominal voltage	24 VAC/DC - 440 VAC (depending on variant)
Rated Current	
External housing material	
Surface treatment	Powder-coated (s. labelling X)
Ambient temperature range extended	-20 °C ≤ Ta ≤ 40 °C -20 °C ≤ Ta ≤ 60 °C
Temperature class	T6 (at Ta +40 °C) / T4 (at Ta +60 °C)
Max. surface temperature	80 °C (at Ta +40 °C) / 100 °C (at Ta +60 °C)
IP protection class	IP67, IP68

3.1 Type Key

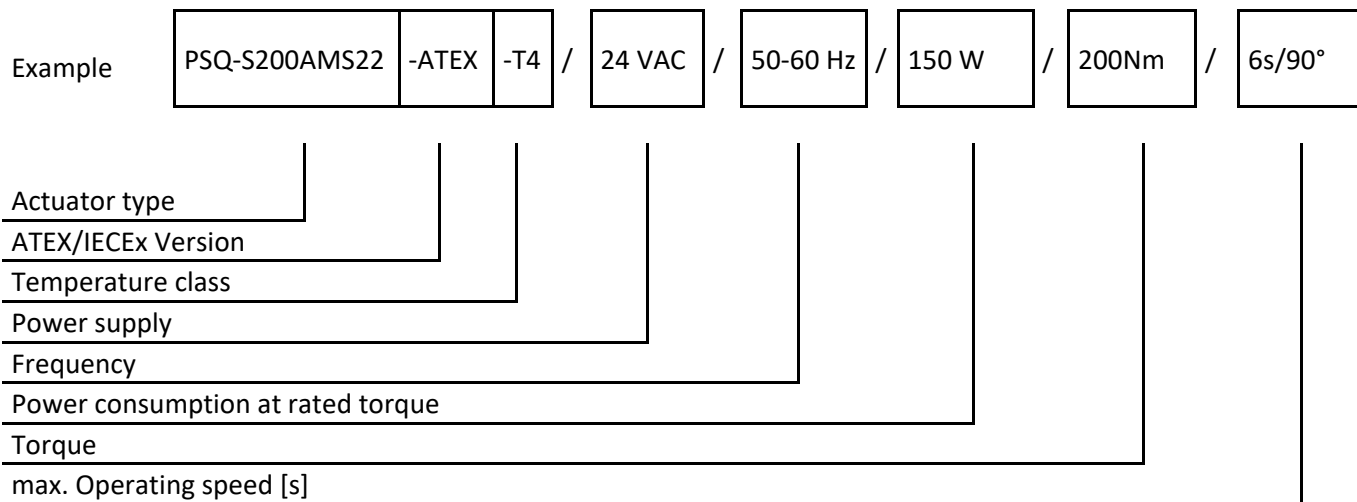

4. Symbols and safety

General Dangers of Non-compliance with Safety Regulations

PS-AMS2 PSQ EX actuators are built to state-of-the-art technology and are safe to operate. Despite of this, the actuators may be hazardous if operated by personnel that has not been sufficiently trained or at least instructed, and if the actuators are handled improperly, or not used as per specification.

This may cause

- danger to life and limb of the user or a third party,
- damage the actuator and other property belonging to the owner,
- reduce safety and function of the actuator.

To prevent such problems, please ensure that these operating instructions and the chapter on “Safety” in particular have been read and understood by all personnel involved in the installation, commissioning, operation, maintenance and repair of the actuators.

Basic Safety Notes

- The actuators may only be operated by skilled and authorized operating personnel.
- Make sure to follow all security advices mentioned in this manual, any national rules for accident prevention, as well as the owner’s instructions for work, operation and safety.
- The isolating procedures specified in these operating instructions must be followed for all work pertaining to the installation, commissioning, operation, change of operating conditions and modes, maintenance, inspection, repair and installation of accessories.
- Before opening the actuator cover, ensure that the main supply is isolated and prevented from unintended re-connection.
- Areas that can be under voltage have to be isolated before working on them.
- Observe EN IEC 60079-14 when installing the actuators.
- Ensure that the actuators are always operated in faultless condition. Any damage or faults, and changes in the operational characteristics that may affect safety, must be reported at once.

Danger Signs

The following danger signs are used in this operating manual:



Caution! There is a general risk of damage related to health and/or properties.



Danger! Electrical voltages are present that may lead to death. Life threatening risks may occur due to electrical voltages!



Danger! This sign warns of hazards posing a risk to health. Ignoring these instructions can lead to injuries.



Caution! Observe precautions for handling. Electrostatic sensitive devices.

Other Notes

- The motor surface temperature may rise when maintaining, inspecting and repairing the actuator immediately after the operation. There is a danger of burning the skin!
- Always consult the relevant operating instructions when mounting PS accessories or operating the actuator with PS accessories.
- Connections for signal in- and output are double isolated from circuits that can be under dangerous voltage.

5. Usage as per specification

- The type PS-AMS PS-AMS2 PSQ EX actuator is a fixed installed device for use in Ex zone 1, 2, 21 or 22.
- The type PS-AMS PSQ-S-EX actuator is not suitable for use in Zone 0 and Zone 20.
- The electrical data shown on the type plate as well as the unit category for the place of use must be observed.
- The operator of an electrical system in a potentially explosive atmosphere must keep the equipment in proper condition, operate it properly, monitor it and carry out maintenance and repair work. See also IEC/EN 60079-17 / IEC/EN 60079-19.
- The PS-AMS2 PSQ EX actuators are constructed exclusively for use as electronic valve actuators. They are designed for assembly with valves and their motorised operation.
- Any other use is considered to be non-compliant. The manufacturer cannot be held liable for any damage resulting from it.
- The actuators can only be used within the limits laid out in the data sheets, catalogues and other documents. Otherwise, the manufacturer cannot be held liable for any resulting damage.
- Usage as per specification includes the observance of the operating, service and maintenance conditions laid down by the manufacturer.
- Not to be regarded as usage as per specification are mounting and adjusting the actuator as well as servicing. Special precautions have to be taken while doing this!
- Mounting and adjustment of the actuator as well as its maintenance are not considered as intended use. Enhanced safety precautions must be implemented in such situations.
- Damages caused by unauthorized modifications carried out on the actuators are excluded from the manufacturer's liability.

5.1 Special conditions

- For safe use, the metallic body of Ex d enclosure must be connected to the existing Protective Earth (PE) network at the installation site in the hazardous areas. During installation and operation, the correctness of the earthing must be periodically inspected, especially in case of possible galvanic corrosion between different metals.
- The painted external enclosure and the position indicator is susceptible to electrostatic charging. To avoid critical electrostatic charges,
 1. the devices must not be installed in the vicinity of highly charge-generating processes.
 2. the devices are only cleaned with damp or antistatic fabric.
- The gap of the flameproof joints is partly smaller than the values of Table 3 for IIC of IEC 60079-1:2014. Information regarding the dimensions of the flameproof joints can be obtained from the manufacturer. Especially, the flameproof joints are not allowed to be repaired!
- During installation, the user shall provide additional clamping of the cable near the Ex e cable glands, outside the enclosure, that pulling is not transmitted to the terminations inside the Ex eb terminal compartment.
- The enclosure may not be opened when energized or when an explosive atmosphere is present.
- The M10x35 special fastening screws have a minimum tolerance 6g and a yield strength of at least 450 N/mm².

6. Storage

For appropriate storage, the following instructions have to be met:

- Only store the actuators in ventilated, dry rooms.
- Store the actuators on shelves, wooden boards, etc., to protect them from floor moisture.
- Cover the actuators with plastic foil to protect them from dust and dirt.
- Protect the actuators against mechanical damage.

7. Operating conditions and installation

- When setting up and operating explosion-protected electrical equipment, care must be taken to ensure protection against harmful environmental influences that restrict the intended use of the equipment. These can be, for example, protection against aggressive liquids or climatic influences. During installation, observe EN IEC 60079-14 and other applicable national standards and regulations at the place of installation.
- The information on the type plate and the applicable documents must be taken into consideration.
- For cable entries with special installation conditions, (see „X“ marking on the cable entry), the relevant instructions given by the manufacturer must be followed.
- The actuators can be operated in the explosion-proof version at ambient temperatures according to the data sheet.
- The duty cycles are according to EN IEC 60034-1, 8: S2 for short-time duty and S4 for modulating operation (for actuator-specific values, see actuator-specific data sheets).
- For protection against moisture and dust, the enclosure rating is IP65 according to EN 60529.

8. Function

The PS-AMS2 PSQ EX electrical quarter-turn actuator is designed for the actuation of quarter-turn valves.

The rotary movement of the output drive is detected by a non-wearing, contactless position monitoring system based on a 12-bit Hall sensor potentiometer and is electronically evaluated. The powerful and energy-efficient brushless DC is regulated and monitored by the electronics. Its torque is transferred to the output drive via compact multi-stage planetary gear.

The torque of the actuator is electronically monitored and limited.

The valve position is indicated by a contactless mechanical position indication in the cover of the quarter-turn actuator.

9. Mechanical assembly

9.1 Mounting the manual override

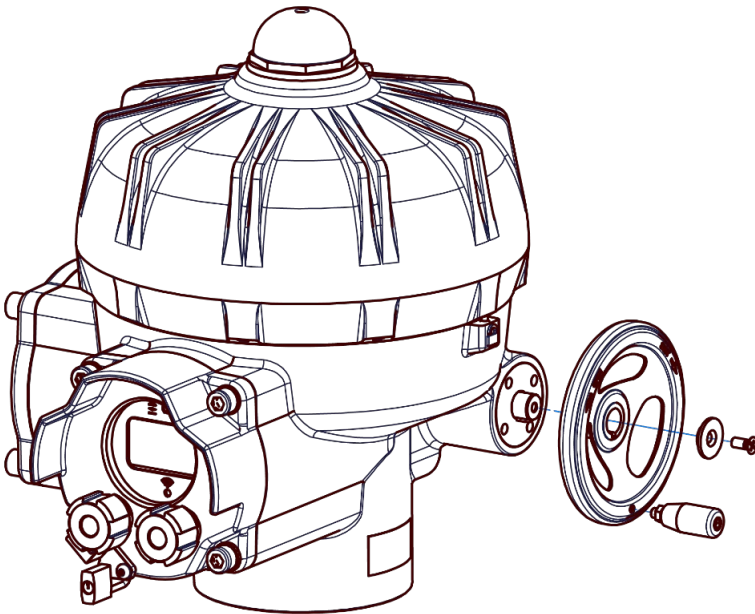

Figure 1: Mounting the handwheel

9.2 Installation positions

The actuator may be installed in any orientation, overhead installation is available on request.

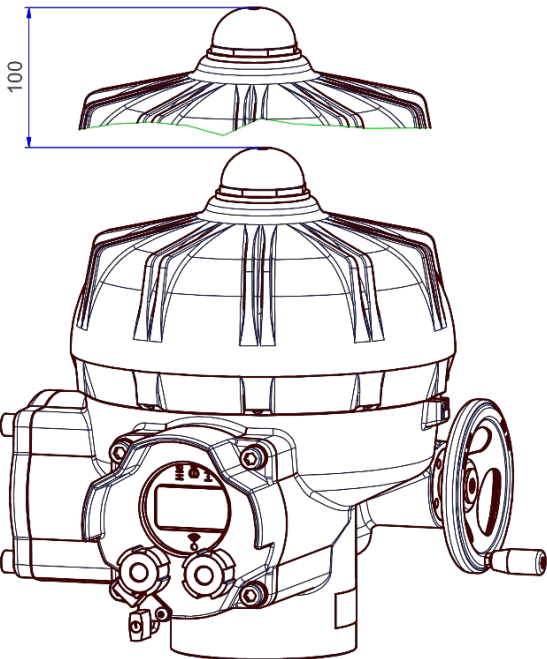

Figure 2: Space required to remove the cover

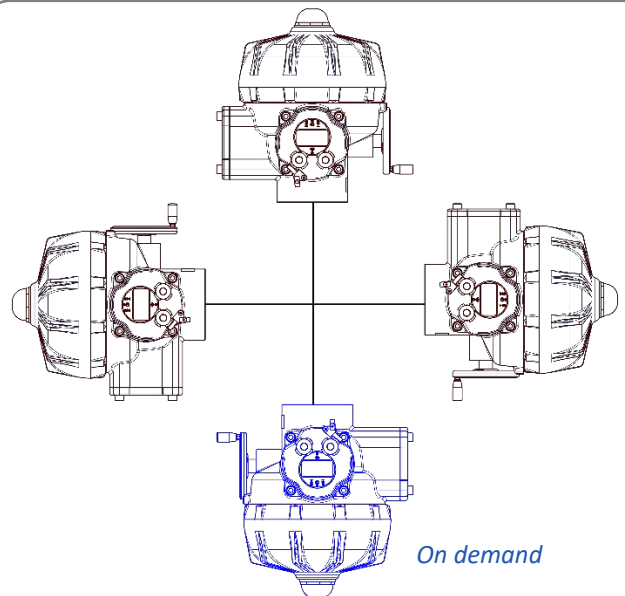

Figure 3: Installation positions

9.3 Flange connection / valve mounting

The quarter-turn actuator is designed for universal mounting on ISO 5211 flanges. The gear contains a double square SW27 to connect the actuator to the valve shaft.

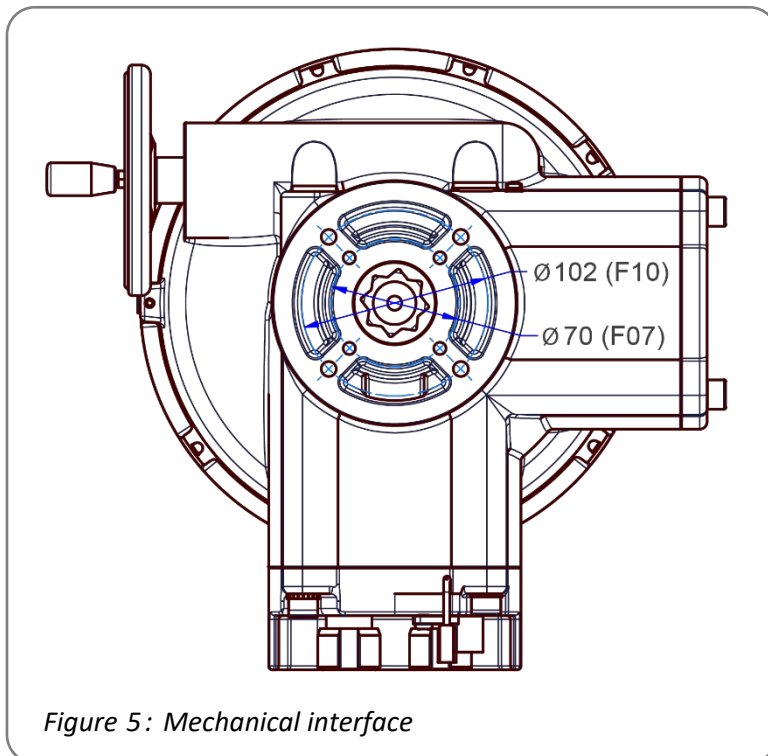

Figure 5: Mechanical interface

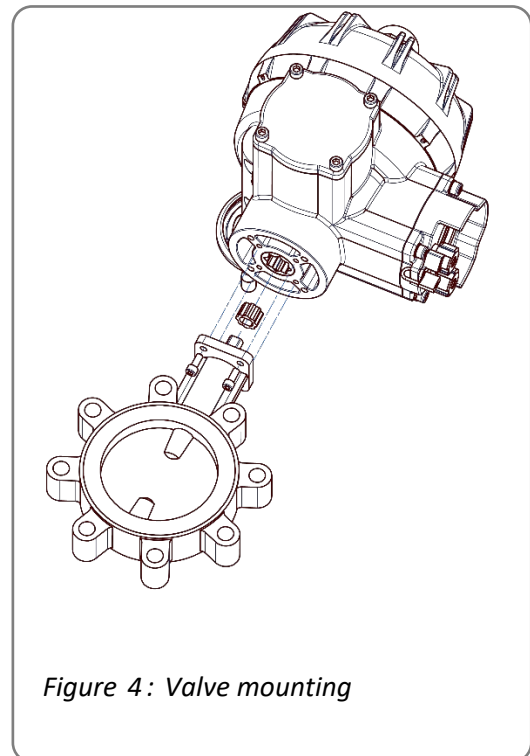

Figure 4: Valve mounting

- Check if the actuator flange suits the valve flange.
- Check whether the double square or drive bush of the actuator matches the design of the valve shaft. If necessary, commercially available adapters can be used to adapt to the valve shaft. If the existing double square is used, the sleeve stop inserted can be removed to prevent it from colliding with the valve shaft.
- Connect the actuator electrically (see 11. Electric supply).
- Position the actuator electrically by means of manual operation (see 12.1 manual operation) so that it matches the position of the valve.
- Clean the surface of the connection components, lubricate valve shaft slightly.
- Attach the actuator to the fitting and fasten it. Tighten the screws in a diagonal sequence according to the required torque.

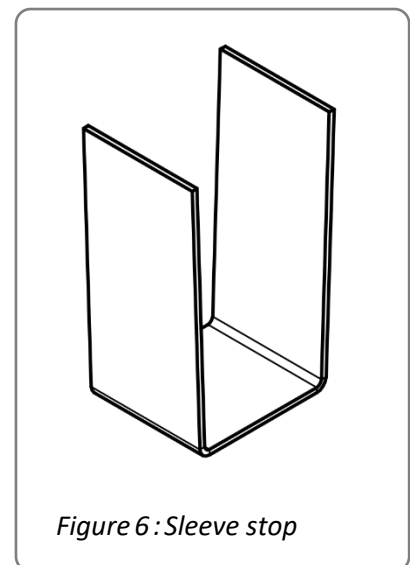

Figure 6: Sleeve stop

9.4 Setting the mechanical stop

Shown is the adjustment of a mechanical stop in closing direction for a valve closing clockwise.



When adjusting the mechanical end stops, the actuator shall be actuated only with the handwheel (not electrically).

- Remove the protective caps (*fig. 7; pos. 3*) from the two adjusting screws.
- Unscrew both hexagon sockets anti-clockwise by approximately 5 turns.
- Move the actuator to the closed position by turning the handwheel clockwise.
- Turn stop screw for closed position (*fig. 7; item 1*) to the stop.
- Move the actuator to the open position by turning the handwheel clockwise
- Turn stop screw for open position (*fig. 7; item 2*) to the stop.
- Refit the screw plugs and consider the tightening torque values, see table below (variant-dependent).

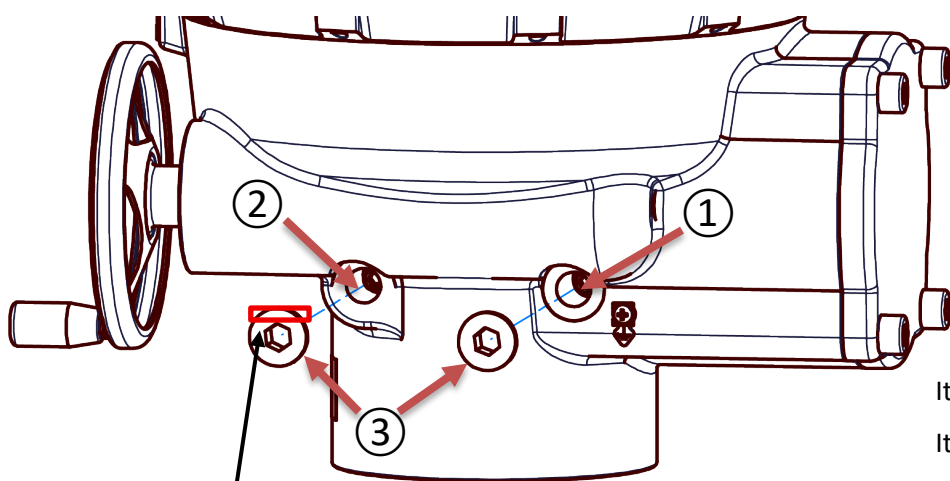

Item 1: Allen screw for CLOSED position

Item 2: Allen screw for OPEN position

Item 3: protective caps

Note: The certificate number can be found on the cable gland.

Thread	ATEX- certificate number	IECEX-CoC	Tightening torque [Nm]
M16x1,5	DNV 22 ATEX 52701X	DNV 22.0069X	35
M16x1,5	CML 18ATEX1320X	IECEX CML 18.0177X	20
M16x1,5	IEP 15ATEX0333U	-	8

Figure 7: Mechanical stop

10. Removing / closing the cover



The cover may only be opened in non-hazardous areas and only in a dry environment.



Take appropriate ESD handling precautions before opening the housing:

- Ground the actuator.
- Before opening the cover, touch grounded housing parts.

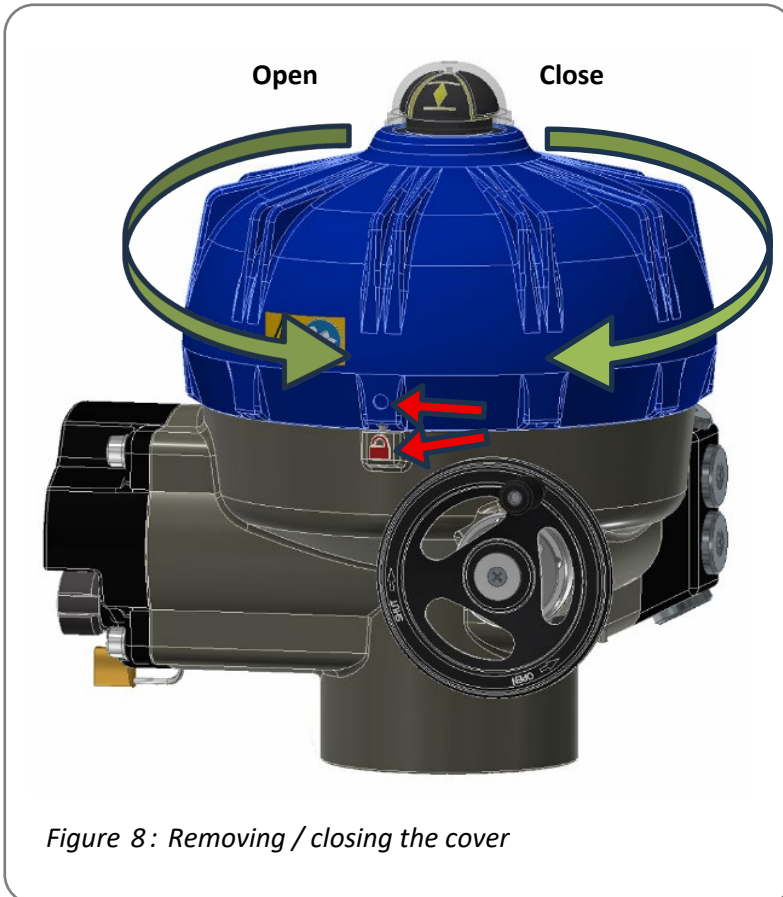

Open:

Loosen the grub screw at the marked point (red arrow) using an Allen key and unscrew the cover anti-clockwise.

Close:

- Place the cover on straight.
- Turn the cover anticlockwise with both hands until the threads engage.
- Carefully screw the cover clockwise with both hands up to the stop. Don't let it get stuck!
- Turn the cover back slightly until the circular mark on the cover is aligned with the lock symbol on the mounting plate and the grub screw fits exactly into the hole.

Secure the cover with the marked grub screw.

Figure 8: Removing / closing the cover

11. Electric supply

11.1 Safety Note

The cover of the electrical connection must be opened for electrical connection (see chapter 10).



During the connection of the mains voltage, this must be disconnected and secured against unintended reactivation!

- Electrical connections shall be implemented only by an electrician and in compliance with DGUV regulation 3 [German accident prevention regulations]!
- Observe EN 60204-1 (VDE 0113 part 1) to ensure human safety, integrity of the assets as well as the proper functioning of the unit.
- The mains connecting cables must be suitably dimensioned to accept the maximum current requirement of the actuator.
- The yellow-green coloured cables may **only** be used for connecting to earth.
- When leading wires through the cable glands on the actuator, their minimum bending radius has to be considered.
- The PS-AMS2 PSQ EX electric actuators do not have an internal electrical power switch. Therefore, a power mains switch has to be provided for installation. It should be installed close to the actuator and should be easy to access for the user. It is important to mark the circuit breaker as this actuator's isolator.
- The building installation must provide over-current protection devices according to DIN VDE 0100-430 / IEC 60364-4-43. Protective measures against electric shock must be implemented in accordance with DIN VDE 0100-410 / IEC 60364-4-41 for the connection of actuators of protection class I or protection class III at 24 VAC / 24 VDC.
- All mains connection lines and control lines must be mechanically secured ahead of the terminals with suitable measures to prevent unintentional loosening. Never install the power supply and the control cables together in one line but instead please always use two different lines.
- The connection to the terminal block is specified by the manufacturer. Strip the insulation from the conductors over a length of 8 mm ... 10 mm. Flexible conductors can be fitted with ferrules. Crimp the wire end ferrules using a crimping pliers and ensure that the test requirements are in accordance with DIN 46228 Part 4. The length of the copper sleeves must correspond to the specified stripping length of the conductors. Rigid or flexible conductors with ferrules can be connected directly without tools. Insert the conductor into the terminal's connection opening up to the stop. For small conductor cross-sections and flexible conductors without ferrules, open the clamping point before inserting the conductor. For this, use a flat-blade screwdriver (recommended tool, see accessories) to press down the integrated actuating push button.

When closing the cover, make sure that no cables are crushed between the housing and the cover.

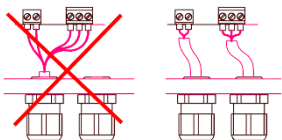

Please protect all of the power supply and control cables in front of the terminals mechanically by using suitable measures against unintentional loosening.

Never install the power supply and the control cables together in one line but instead please always use two different lines.

 PE earth connection has to be connected to gear casing at the marked position PE!



The connection for equipotential bonding is made at the external equipotential bonding connection of the actuator. (see fig. 13).

Ensure that all connecting cables are stripped to the correct length so that they are protected against electric shock.

11.2 Opening and closing the Ex-e room

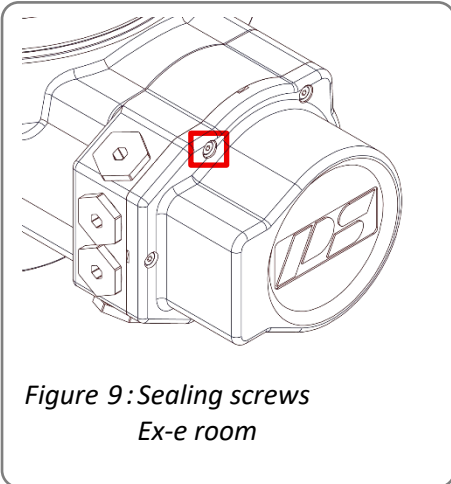

Open:

First loosen all screws with a suitable screwdriver, then unscrew them completely from the connection compartment housing. The screws are protected against loss. Remove the cover carefully so as not to damage the seal.

Close:

Place the cover on the connection compartment housing and press lightly. Tighten the screws gently and then crosswise. It must be ensured that all screws are firmly tightened to guarantee protection against ingress of water and dust in accordance with EN 60529 to IP67.

The tightening torque for the Ex-e cover is 3 Nm.

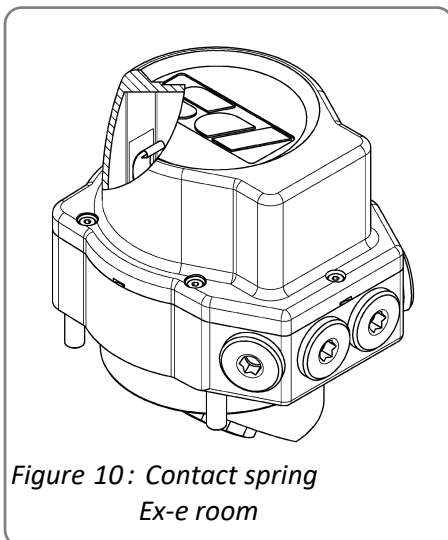

To ensure proper grounding of the cover connection compartment, check the contact of the spring on the open surface in the cover connection compartment!

11.3 Connection of cable glands Ex-e room

The connection to the Ex-e room is designed with screw plugs as standard and can be ordered with cable glands as an accessory option. When loosening the screw plugs or cable glands, the torques specified below must be observed.

Note: If you use your own cable glands, they must be suitable for use at the intended position and explosion-proof!

Unused cable glands must be closed with a suitable blind plug!

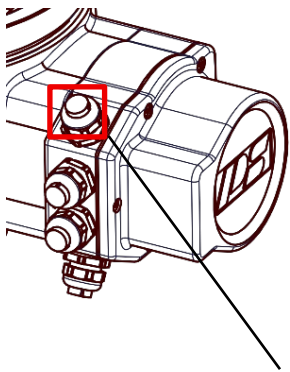

Thread	IP	ATEX- certificate number	IECEX-CoC	Tightening torque [Nm]
plug screw M25x1,5	IP67	PTB 06 ATEX 1032 X	IECEX PTB 16.0025X	5 Nm
plug screw M25x1,5	IP68	CML 18ATEX1320X	IECEX CML 18.0177X	30 Nm
plug screw M25x1,5	IP67	PTB 13 ATEX 1015 X	IECEX PTB 13.0034X	3 Nm
plug screw M25x1,5	IP68	PTB 04 ATEX 1112 X	IECEX PTB 13.0027X	10 Nm

Note: The certificate number can be found on the cable gland.

Figure 11: Cable glands Ex-e room

11.4 Opening the side EXd cover / PSC.3

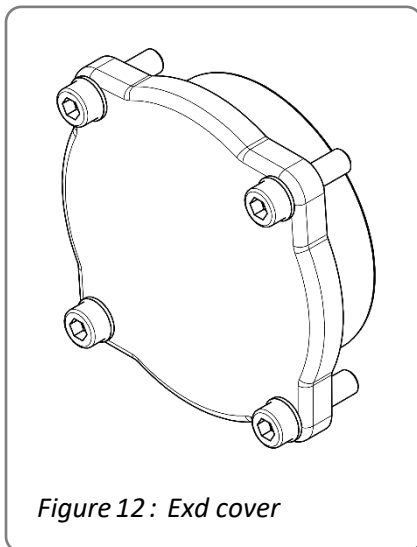
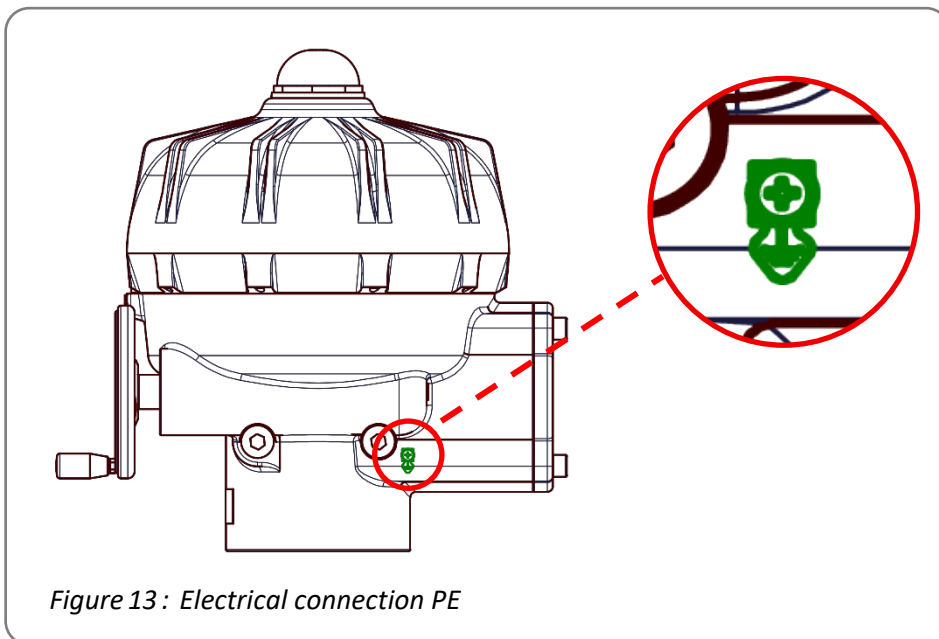

Figure 12: Exd cover

11.5 Electrical connection PE



11.6 Connecting mains

Attention: Mains voltage, mains frequency and available power must be compliant with the data on the name plate!

Note: For 24V, a cable cross-section of at least 1.5 mm² must be used.

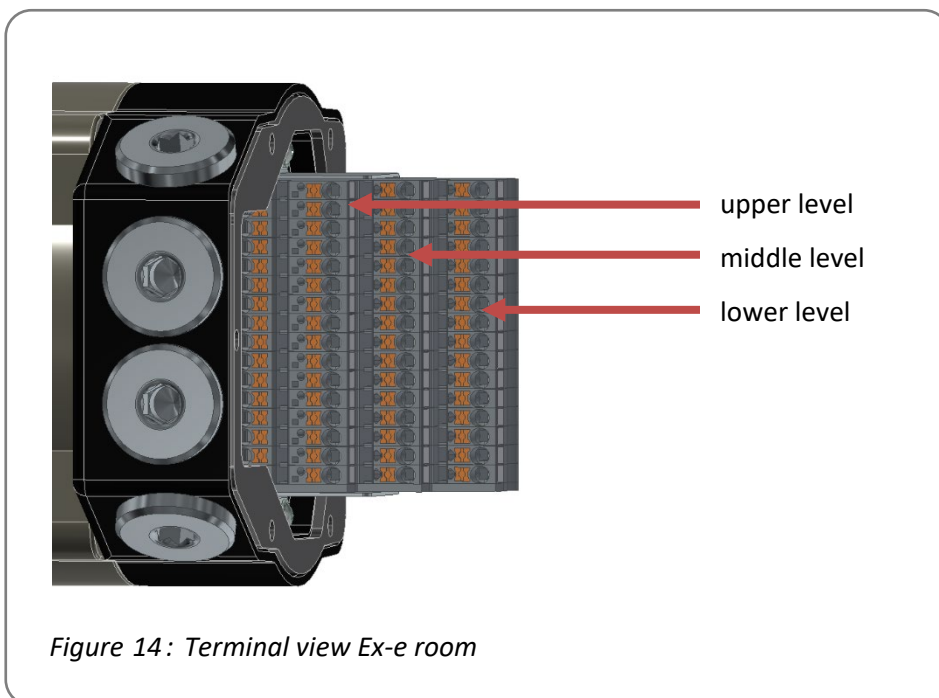

11.6.1 Connection to terminals on the control board of the actuator

11.6.2 Connection diagram

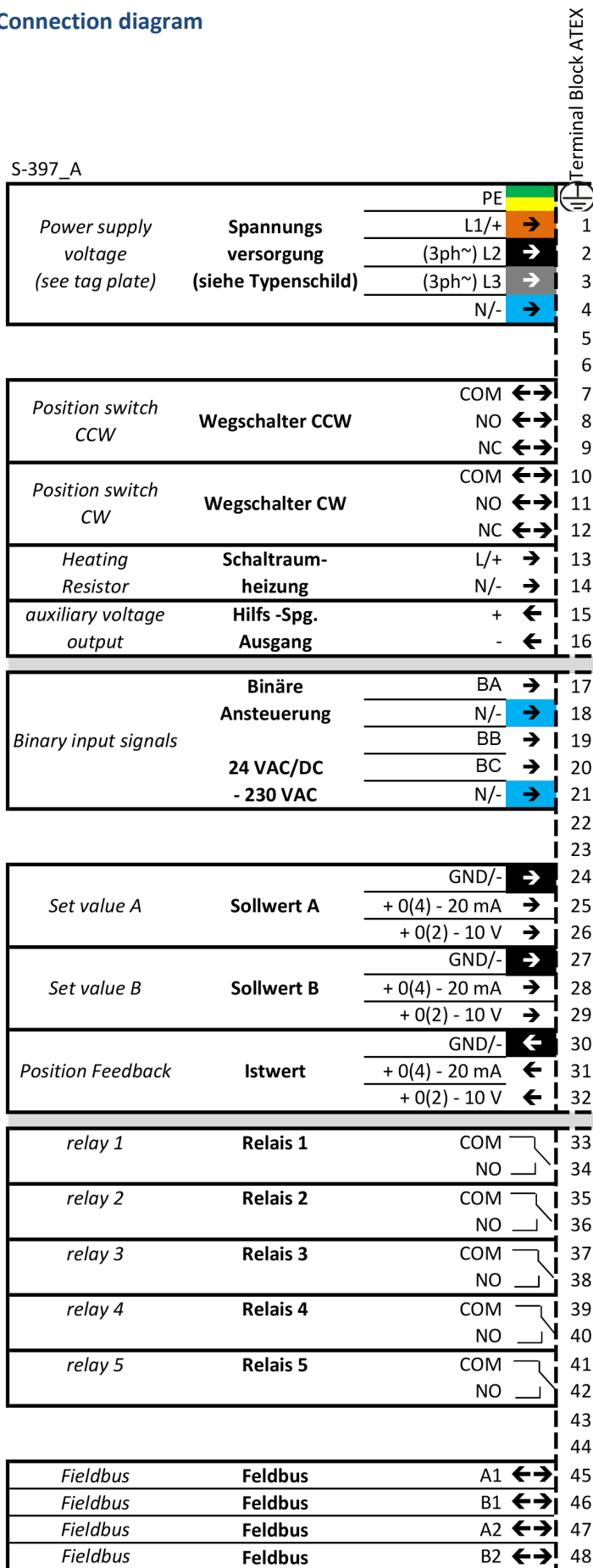

Figure 15 : Connection diagram

11.6.2.1 Supply voltage 24 VDC

Connection to the control board with reverse polarity protection integrated.
Connect power supply 24 V DC to terminals 1(+) and 4(-).

11.6.2.2 Supply voltage 24 VAC

24 VAC connection with integrated AC/DC converter.
Connect power supply 24 V AC to terminals 1 and 4.

11.6.2.3 Supply voltage 100-240 VAC 1~ (optional)

Connection to the wide-range power converter unit for 1~ AC
Connect power supply 100-240 VAC 1~ to terminals 1(L1) and 4(N).

11.6.2.4 Supply voltage 200-440 VAC 3~ (optional)

Connection to the wide-range power converter unit for 3~ AC
Connect power supply 200-440 VAC 3~ to terminals 1(L1), 2(L2), 3(L3).

Two phases of the power supply must be connected to the power supply unit to distribute the mains load. Unused cables must be isolated.

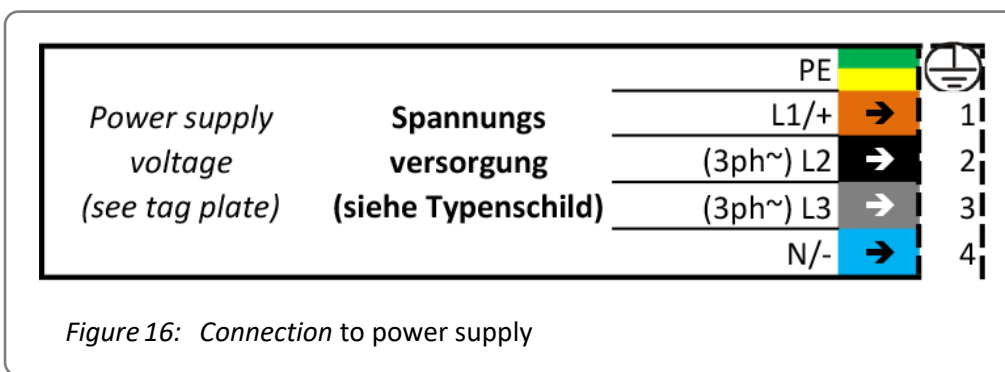

11.7 Interfaces

11.7.1 Inputs with galvanic isolation

11.7.1.1 Analogue Set value A

Connection of the parameterisable set value A as position set value, range 0 (4)-20 mA or 0 (2)-10 V.

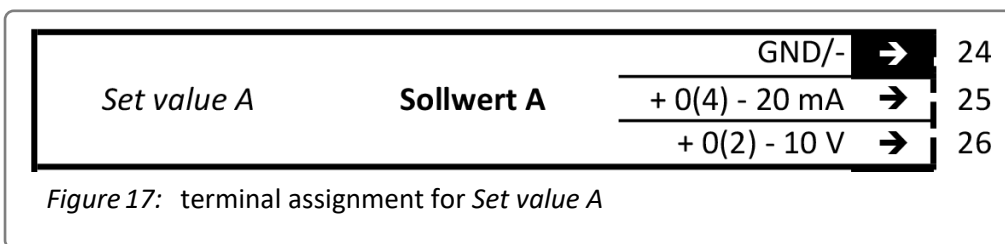

11.7.1.2 Analogue Set value B

Connection of the parameterisable set value B, output from a process sensor as process actual value for use with PSIC or as set value for the speed controller, range 0 (4) -20 mA or 0 (2)-10 V

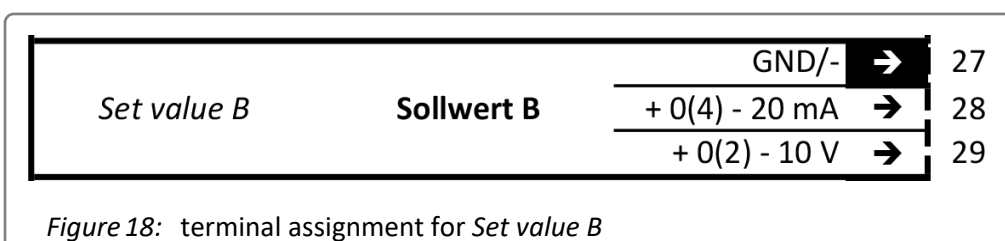

11.7.1.3 Binary input ports BA / BB / BC

The actuator has galvanically isolated binary multi-voltage input ports, BA/BB have a common neutral line connection COM. BC is galvanically isolated from BA/BB.

If a voltage is present at a binary port, the system drives to the parameterised corresponding position regardless of the analogue or digital set value applied.

Prioritisation is from BA (highest priority) to BC (lowest priority). Exception when parametrizing BA PWM.

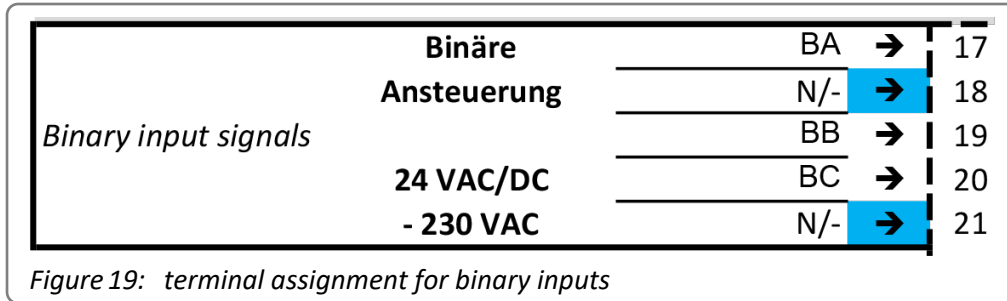

11.7.1.4 Fieldbus interface (optional)

A fieldbus interface is available as an option for the PS-AMS2 PSQ EX actuators. If you have any questions, please contact your PS Automation representative.

11.7.2 Outputs with galvanic isolation

11.7.2.1 Analogue Position Feedback

Connection of the parameterisable position feedback, range 0 (4)-20 mA or 0 (2)-10 V.

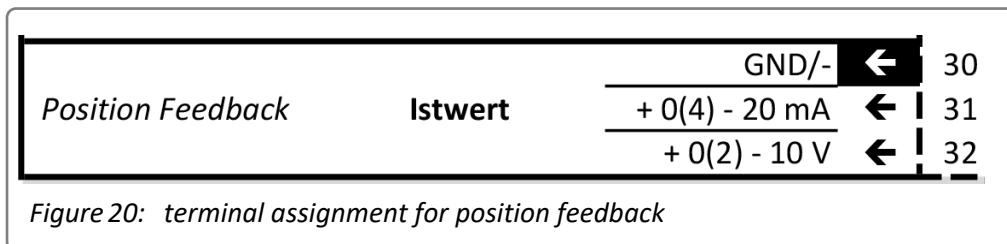

11.7.2.2 Auxiliary voltage output (optional)

This output provides a regulated voltage of 24 VDC max. 42mA, e.g. for the direct supply of binary signal inputs.

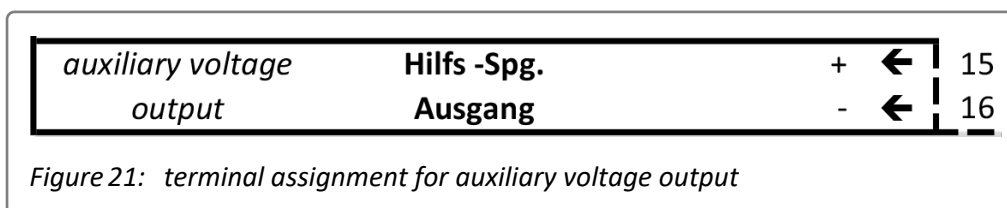

11.7.2.3 Potential-free position signal switches (optional)

For PS-AMS2 PSQ EX, two potential-free limit switches for position feedback are factory-fitted as an option available:

Position Signal Switches	2WE	Potential-free position signal switches with silver contacts (0,1 A - 5 A Schaltstrom)
Position Signal Switches Gold	2WE Gold	Potential-free additional position switches with gold contacts (0,1 mA - 100 mA switching current)

Connection goes to terminal 7-12 in the terminal box.

Position switch CCW	Wegschalter CCW	COM ↔	7
		NO ↔	8
		NC ↔	9
Position switch CW	Wegschalter CW	COM ↔	10
		NO ↔	11
		NC ↔	12

Figure 22: terminal assignment for position switches

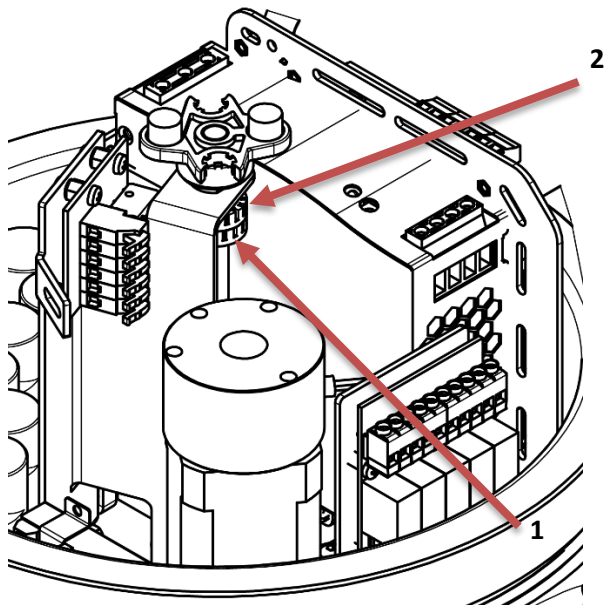

The switching cams for activating the position switches are mounted on the switching shaft by means of a slip clutch. At actuators closing clockwise, the lower cam (1) activates the switch for closing direction, the upper cam (2) for opening direction.

The cam key is attached to the cover of the local control unit as supplied.

Figure 23 : Adjusting of the cams

11.7.2.4 Heating resistor

The PS-AMS2 PSQ EX actuators are equipped with an internally wired heating resistor. It is intended for outdoor installations, with severely fluctuating ambient temperature or high levels of humidity in order to prevent condensation in the interior of the actuator.

11.7.2.5 Potential-free signal relays with changeover contact 1-5 (optional)

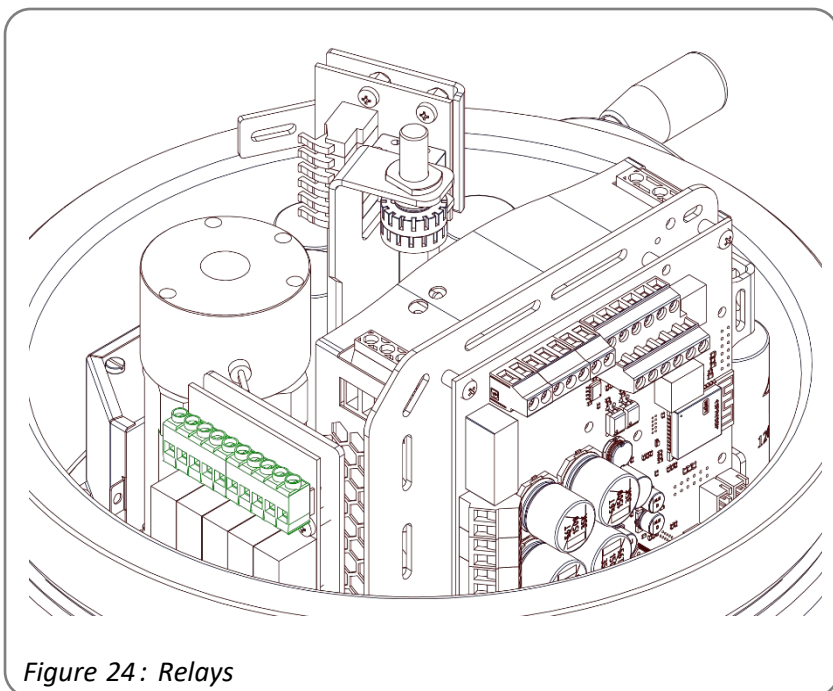

Figure 24: Relays

For a detailed description of the relay settings, please refer to the PS-AMS2 PSCS.3 user manual.

Connection for parameterisable feedback information, range 24 V AC/DC @ 0.1 A - 1 A

<i>relay 1</i>	Relais 1	COM	33
		NO	34
<i>relay 2</i>	Relais 2	COM	35
		NO	36
<i>relay 3</i>	Relais 3	COM	37
		NO	38
<i>relay 4</i>	Relais 4	COM	39
		NO	40
<i>relay 5</i>	Relais 5	COM	41
		NO	42

11.7.2.6 Communication Interface

The actuator has a TTL communication interface, enabling communication with the actuator via the AMS.2-USB communication cable and the PSCS.3 communication software.

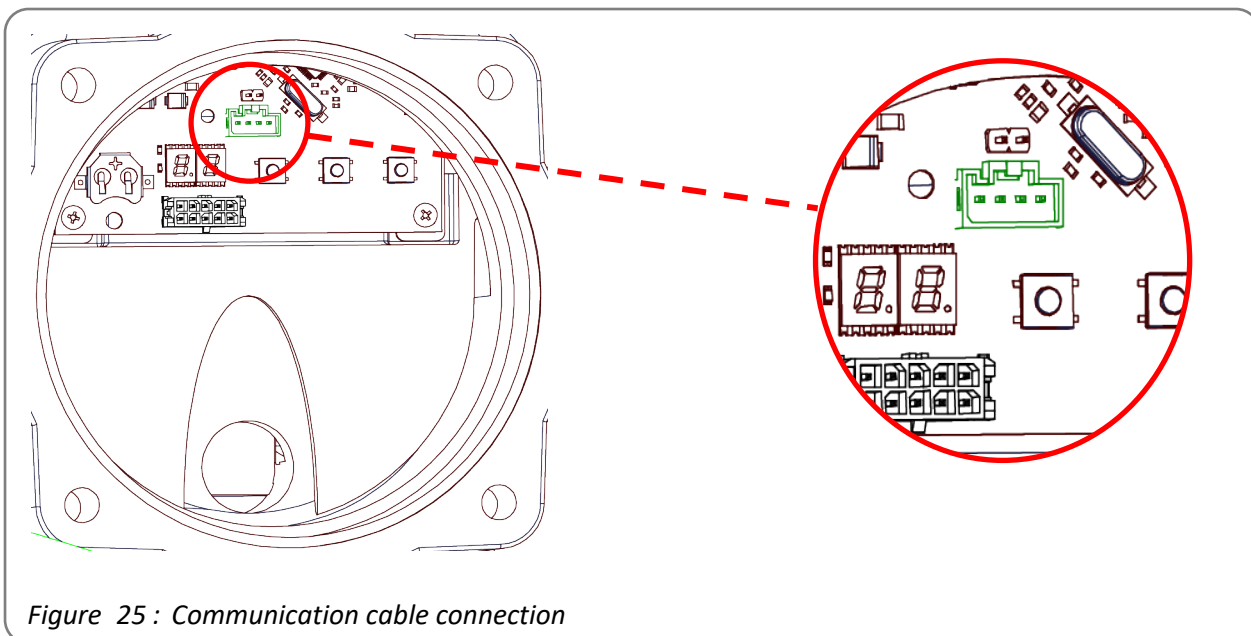

Figure 25 : Communication cable connection

12. Operation

12.1 Manual operation

The handwheel moves the complete planetary gear set via a worm shaft. It does not move during automated operation but is available in each position without clutching. Turning the handwheel clockwise turns the actuator output clockwise (when viewed from above).



Attention: If the PSCP failsafe is active (option), manual operation is only possible after the failsafe position has been reached and if configured; see PSCS.3 operating instructions.

Attention: In modulating operation, the actuator counteracts the manual override. In this case, to adjust the actuator manually, the power must be turned off, the selector switch on the PSC.3 local control unit (optional) must be set to “OFF,” or manual operation must be enabled

12.2 Mechanical position indication

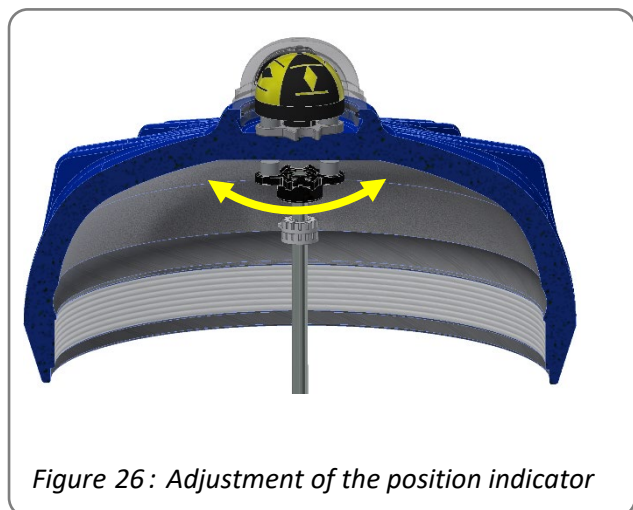

Figure 26 : Adjustment of the position indicator

A contactless mechanical position indicator is installed underneath the dome on the cover of the actuator. The orientation of the indicator can be adapted to the valve by turning the magnetic driver under the cover to the corresponding position. (Loosen the set screw first, then retighten it).

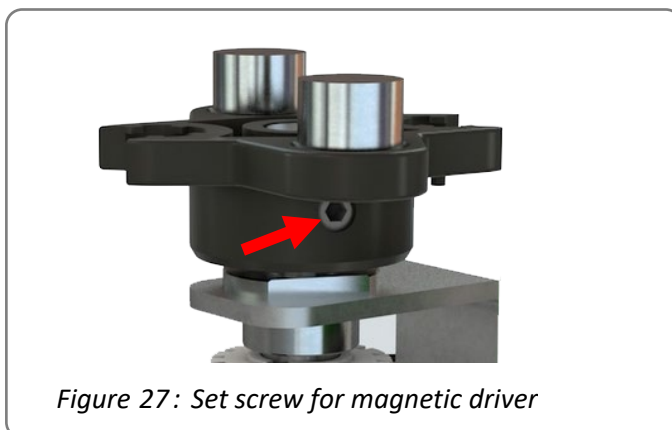
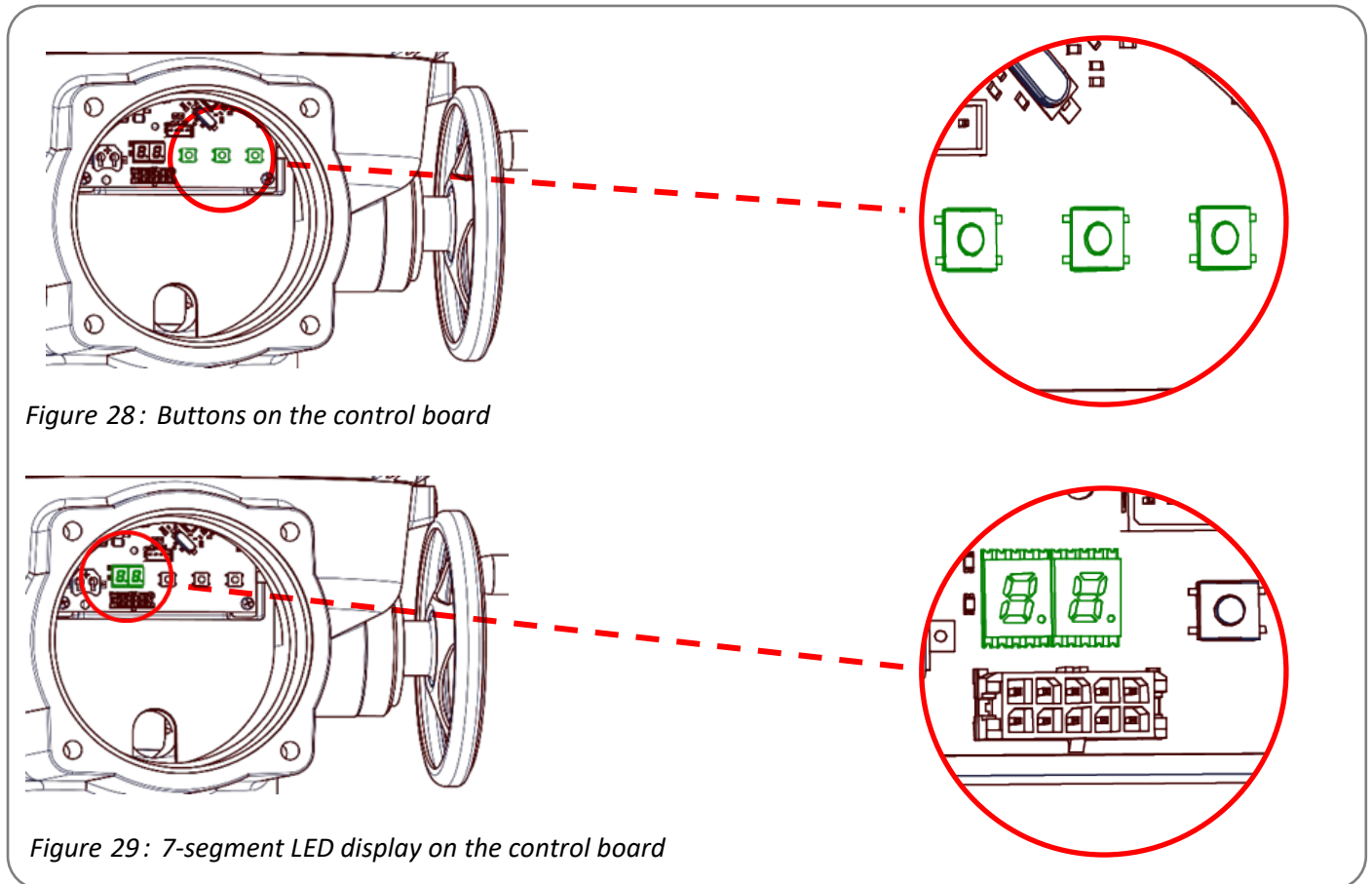

Figure 27 : Set screw for magnetic driver

13. Status display / Commissioning elements

There is an integrated control unit located on the PS-AMS2 PSQ EX control board, comprising a 7-segment LED display and three push buttons.



13.1 Actuator position / status / error messages

The 7-segment display shows the current status of the actuator.

13.1.1 actuator disabled



The actuator is disabled.

- Press and hold the UP button (for 5 seconds) to switch to automatic mode
- Press the UP & DOWN buttons (for 5 seconds) to switch to manual mode (13.1.3)
- Press the ENTER button (for 5 seconds) to enter the function menu

13.1.2 Auto Mode



The actuator is activated and is adjusting to the specified position. The 7-segment display shows the valve position as a percentage (0-99) once the actuator has been commissioned. Otherwise, the actuator position is displayed as a percentage of the total travel distance. The dot indicates whether the actuator is moving.

- Pressing the DOWN button (for 5 seconds) deactivates the actuator (13.1.1)
- Press the UP & DOWN buttons (for 5 seconds) to switch to manual mode (13.1.3)
- Press the ENTER key (for 5 seconds) to access the function menu (13.1.4)

13.1.3 Manual mode



The actuator can be moved using the buttons. The 7-segment display shows the valve position as a percentage (0-99) once the actuator has been commissioned. Otherwise, the actuator position is displayed as a percentage of the total travel distance. Manual mode is indicated by both dots on the 7-segment display.

- The DOWN button moves the actuator towards the closed position (0%)
- The UP button moves the actuator towards the open position (100%)
- Pressing the ENTER button (for 5 seconds) exits manual mode and returns to the previous state

13.1.4 Function menu



The function menu allows to access functions directly on the actuator. It also enables the commissioning process to get started.

To access the function menu, press and hold the ENTER button for 5 seconds. Select the functions using the UP / DOWN buttons and start them by pressing the ENTER button.

The dot indicates whether a function has been activated.

The system automatically exits the function menu if there is no activity for 60 seconds. Alternatively, you can exit the menu by pressing the ENTER button again for 5 seconds.

Functions

P0	Wi-Fi Auto	Enables (P0.) or disables (P0) Wi-Fi. When set to this option, the Wi-Fi switches off automatically after a certain period of time if no device is connected to the actuator. This prevents the signal from remaining active continuously.
P1		
P2		
P3		
P4		
P5	set value	Switches the set value between current (P5) and voltage (P5.)
P6	Position feedback	Switches the actual value between current (P6) and voltage (P6.)
P7	End position: Open	Sets the current actuator position as the end position (P7.) for the Open position.
P8	End position: Closed	Sets the current actuator position as the end position (P8.) for the Closed position.
P9	Automatic commissioning torque	Starts automatic commissioning To do this, at least one torque limit must be set (P7.&P8 / P7&P8. / P7&P8). For further details, see Chapter 14 - Commissioning.

13.1.5 Status display



If there is a change in status or an error message, the corresponding status number is displayed. The 7-segment display switches between the NE107 code and the status number.

NE107	Status no.	Message
C	1	Automatic commissioning running
C	2	Not commissioned
F	7	System error
F	9	CRC fault
S	17	Overvoltage
S	8	Over-temperature
S	16	Under-temperature
C	5	Mains power failure
S	11	Undervoltage
C	15	actuator disabled
C	14	Torque error CLOSE
C	4	Torque error OPEN
S	6	Set value B error
S	3	Set value A error
C	13	End position not reached
C	12	End position overrun
C	18	New attempt
C	19	On

13.2 PSC.3 local control panel (optional)

The PSC.3 local control unit allows manual operation of the actuator, adjustment of actuator parameters and display of diagnostic information. A display and LEDs show the actuator position and status. Information on the operation of the local control can be found in the “PSC.3 Local Control for PS AMS2 PSQ EX” operating instructions.

13.3 Operation

13.3.1 Power regulation

During operation, the power consumption of the actuator is regulated and limited. This prevents the actuator controller and the power converter from being overloaded at short operating times with high torque levels.

Upon reaching the maximum power limit, the motor reduces its rotational speed in order to continue to generate the required torque.

Note: When the power regulation is active, the operating time will increase!

13.3.2 Torque regulation

If the maximum torque is reached apart from the stored end positions, the actuator limits the rotational speed until it comes to a standstill. The actuator control keeps the torque constant for a defined period of time and then reports a torque error or tries (three times if the setting is ‘Retry’ or indefinitely if the setting is ‘Endless’) to travel back and pass the detected hard point.

The torque of the output drive will then be maintained through the integrated holding brake.

14. Commissioning



The electrical connection and commissioning with mains voltage applied may only be carried out by trained specialist personnel!

Do not touch any connection lines during commissioning!



- Before the first commissioning, the equipment must be checked for its suitability in the corresponding zone on the basis of its marking. The values indicated on the type plate and in the applicable documents must not be exceeded.
- Commissioning and use may only be carried out if the equipment is installed within the system in a functional, undamaged and clean condition.
- If potential-free additional limit switches have been ordered as an option, open the cover to adjust the switching cams (see 10); otherwise, mount the actuator on the valve and connect the electric supply (see 11).
- Perform automatic commissioning.
- Close the cover (see 10).

14.1 Automatic commissioning

- For automatic commissioning, at least one torque limit position must be set.
- If both end positions are set to torque, the actuator rotates in both directions until torque is detected and then saves these positions. The programmable angle of the actuator is adjusted accordingly.
- If only one end position is set for torque, the actuator first moves in the direction of that end position until torque is detected, and saves this position. The position of the end position is calculated from the parameterised angle. The actuator checks whether this position is within the actuator's range; if not, the angle is reduced. The end position is then approached to ensure smooth operation.

14.2 Manual commissioning

For manual commissioning, e.g. for two end positions, see the operating instructions for the PS-AMS2 PSCS.3, PS-AMS2 PSCS-WIFI or PS-AMS2 PSC.3.

15. WLAN

The actuator allows to adjust all settings wirelessly via Wi-Fi and view diagnostic information. See PS-AMS2 PSCS-WIFI operating instructions.

16. Diagnosis

The actuator is equipped with comprehensive diagnostics functionality which can be used to optimise the process and carry out a targeted assessment in the event of an error.

During operation, the actuator records various diagnostic data.

For a detailed description of the stored data and how to use the diagnostics function, please refer to the PS-AMS2 PSCS.3 or PS-AMS2 PSC.3 operating instructions.

17. Maintenance and Servicing

The actuators are maintenance-free if used under the operating conditions as designated in the data sheet. The gearboxes are lubricated for life and do not require further lubrication.



Caution!

During maintenance and repair the actuator must not be operated electrically.

Personnel carrying out work and maintenance and servicing must be skilled and familiar with the work.

17.1 Cleaning

The actuators should be cleaned dryly. Please do not use cleaning products containing solvents, as these may damage the lettering on the safety labels and the type plate, rendering them illegible. The actuator must not be operated during the cleaning process.

17.2 Servicing

Defective actuators should be returned to our plant in Bad Duerkheim, Germany, or to our representatives for repair (see 17.4).

17.3 Spare parts

Defective actuators should be returned to our plant in Bad Duerkheim, Germany, or to our representatives, to be checked for damages and their possible causes (see 17.4).

17.4 Service address

PS-Automation GmbH
Philipp-Krämer-Ring 13
D-67098 Bad Dürkheim

Tel.: +49 (0) 6322/ 94980-0
Mail: service@ps-automation.com
<http://www.ps-automation.com/>

18. Decommissioning and disposal

- Disconnect the mains supply and ensure that it is secured against an accidental switching-on.
- Open the cover.
- Remove external electrical connections.
- Take off the actuator from the valve.

Disposal

For its disposal, the product should be treated as waste containing electrical and electronic equipment and should not be disposed of as household waste.



For disassembly please contact our plant in Bad Dürkheim.



In accordance with 2012/19/EU on waste electrical and electronic equipment (WEEE), the devices described here may not be disposed of via municipal waste disposal companies.

If you are unable or unwilling to arrange for the equipment to be disposed of by a specialist company, you may return the equipment to the manufacturer, who will then ensure that the equipment is disposed of properly for a flat fee.

19. Accessoires

Accessories/ Options	Add'l Position Switches *	2WE	Potential-free additional position switches with silver contacts (0.1 A - 5 A switching current)
	Add'l Position Switches Gold*	2WE Gold	Potential-free additional position switches with gold contacts (0.1 mA - 100 mA switching current)
	Integrated process	PSIC	Enables the autonomous control of a process so that an external controller is not required, on request
	Fail-Safe*	PSCP	Emergency power supply based on supercapacitors, safety position OPEN, CLOSED or free defined position
	Fieldbus Interface*		Digital transmission of nominal and actual value per mill or percent, report of monitoring and diagnostic data using PROFIBUS-DP, CANopen, PROFINET, MODBUS-RTU interfaces. additional interfaces available on request
	Local Control*	PSC.3	Illuminated display to show the actuator status and lockable selector to switch between modes automatic manual process ON/OFF, STOP and parameter menu Control buttons for manual movement, menu operation and adjustment of parameters. Display of diagnostic information. Also available for mounting separately from the actuator (Modbus Connection, Master/Slave)
	Rotational speed controller, set value B		External regulation of the rotational speed via set value B.
	Relay module*		5 potential-free relays with changeover contacts for reporting parameterisable events. Suitable for switching currents 0.1 A to 1 A at a voltage of 24 VAC/DC
	Increased IP enclosure	IP	Increased enclosure IP68 available**

*not retrofittable

**IP68, no ingress of dust and suitable for continuous immersion in water up to 6 m and 96 h

20. Declaration of incorporation of part completed machinery and EC declaration of conformity in compliance with the directives on EMC and low voltage

Original declaration of incorporation for incomplete machines and EU declaration of conformity

We,

**PS Automation GmbH
Philipp-Krämer-Ring 13
D-67098 Bad Dürkheim**

declare on our sole responsibility that the electric actuator of the series

PS-AMS PSQ-S*AMS2*-*-*

as an incomplete machine meets the requirements of the

EC Machinery Directive 2006/42/EG

The actuators of the series are intended for assembly with valves. Commissioning is prohibited until it has been ensured that the entire machine complies with the provisions of the applicable Machinery Directive. The technical documentation has been prepared per Annex VII Part B.

The actuators mentioned above continue to comply with the requirements if the following EU directives:





2014/30/EU	Electromagnetic compatibility
2014/34/EU (-ABl. L 86 / 29.03.2014-)	Equipment and protective systems intended for use in potentially explosive areas
2014/35/EU	Low voltage directive
2014/53/EU	Radio equipment and repealing directive
2011/65/EU + 2015/863/EU	RoHS directive

des Weiteren wurden die folgenden harmonisierten Normen angewandt:

EN IEC 61000-6-1: 2019	Electromagnetic compatibility (EMC) Generic standards - Immunity standard for residential, commercial and light-industrial environments
EN IEC 61000-6-4: 2018	Electromagnetic compatibility (EMC) Generic standards - Emission standard for industrial environments
EN 61010-1:2010 + A1:2019 + A1:2019/AC:2019	Safety regulations for electrical measuring, control Regulation and laboratory equipment
EN 301 489-1 V2.2.3:2019-11	ElectroMagnetic Compatibility (EMC) standard for radio equipment and services - Part 1: Common technical requirements
EN 301 489-17 V3.3.1:2024-09	ElectroMagnetic Compatibility (EMC) standard for radio equipment and services - Part 17: Specific conditions for Broadband and Wideband Data Transmission Systems
EN 300 328 V2.2.2:2019-07	Wideband transmission systems - Data transmission equipment operating in the 2,4 GHz band

EN IEC 60079-0:2018/AC:2020-02	Explosive atmospheres - Part 0: Equipment - General requirements
EN 60079-1:2014/AC:2018-09	Explosive atmospheres - Part 1: Equipment protection by flameproof enclosures "d"
EN IEC 60079-7:2015/A1:2018	Explosive atmospheres - Part 7: Equipment protection by increased safety "e"
EN IEC 60079-31:2014	Explosive atmospheres - Part 31: Equipment dust ignition protection by enclosure "t"

Actuators of the series have the following marking and main protection class:

 II 2G Ex db eb IIC T4 Gb	or
 II 2G Ex db eb IIC T6 Gb	or
 II 2D Ex tb IIIC T80 °C Db	or
 II 2D Ex tb IIIC T130 °C Db	

Production quality assurance in accordance with

2014/34/EU

Certified by

CE₁₂₃ TPS 22 ATEX 110398 0002 X
TÜV SÜD Product Service GmbH (0123)
Ridlerstraße 65, 80339 München Germany

X 

Andreas Reuter
Geschäftsführung

Bad Dürkheim, 21.10.2025

WARNHINWEIS!

Es liegt in der Verantwortung von Auslegung, Beschaffung, Montage und Betreiber, bei der Inbetriebnahme spezielle Vorgaben und Einsatzgrenzen zu beachten, damit die oben genannten Regelwerke anwendbar sind. Diese speziellen Vorgaben und Einsatzgrenzen geben wir auf Anfrage bekannt; sie sind auch in unseren Betriebs- und Wartungsanleitungen enthalten.

Our representatives:

Italy

PS Automazione S.r.l.
Via Pennella, 94
I-38057 Pergine Valsugana (TN)
Tel.: <+39> 04 61-53 43 67
Fax: <+39> 04 61-50 48 62
E-Mail: info@ps-automazione.it

India

PS Automation India Pvt. Ltd.
Srv. No. 25/1, Narhe Industrial Area,
A.P. Narhegaon, Tal. Haveli, Dist.
IND-411041 Pune
Tel.: <+ 91> 20 25 47 39 66
Fax: <+ 91> 20 25 47 39 66
E-Mail: sales@ps-automation.in

To find out more about all our sales partners and subsidiaries please scan the QR code below or visit our website:
<https://www.ps-automation.com/ps-automation/locations/?lang=en>



PS Automation GmbH

Philipp-Krämer-Ring 13
D-67098 Bad Dürkheim
Tel.: +49 (0) 6322 94980-0
not_found
www.ps-automation.com

