

PS-AMS2 PSQ EX

The intelligent explosion-proof quarter-turn actuator up to 200 Nm



Optimized gearbox with brushless motor for energy-efficient and application friendly operation

New compact actuator housing

WLAN access Point integrated for easy and wireless parameterisation with mobile devices*

Fail-safe device PSCP can be integrated under the main cover*

Hall-sensor for contactless and non-wearing position monitoring

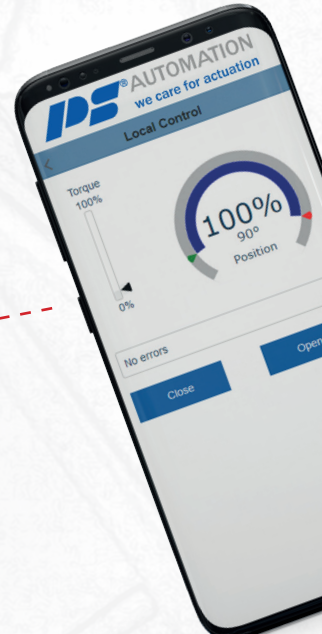

Electrical terminal compartment

Local control with illuminated multilingual LCD display and knob operation*

Design is still in development



Optional accessories

(fully integrable under the housing)

- **Wide-range** power supply units for various input voltages, 24 VAC, 100-240 VAC, 200-440 VAC
- Five freely-programmable **monostable relays** switch outputs (bistable on demand)
- **Fieldbus-ready** e.g. Profibus DP, CANopen
- **Local Control Unit** with knob operation, live-monitoring and password protection
- **Process controller** for independent process control with external process sensor
- **Advanced diagnosis functions** with additional sensors, e.g. temperature and humidity sensor
- **Torque measurement** via Hall sensor

*optionally available

PS-AMS2 PSQ EX

Basic configuration

- New **24 VDC AMS.2 actuator control** with continuous monitoring of all functions
- **Adjustable valves parameters:** the cut-off, angular travel, shut-off-minimum and others!
- **Wide-range binary ports** 24-230 V AC / DC for 3-point-control
- **Software-based speed control** for optimized motion profiles, reduced pressure shocks, and improved control accuracy — configurable via PSCS.3 software or additional setpoint signal.
- **7 segment display** for parameterisation using push buttons directly on the main board **Automatic commissioning** for easy and quick valve adaptation
- Galvanically isolated **analogue interface** 0(4)-20 mA / 0(2)-10 V
- **Contactless position indicator** for reliable tightness

Technical Data

PSQEX200AMS22

Device category	II 2G II 2DG	
EU Type Examination Certificate	TÜV-A 25ATEX0103 X	
ATEX directive gases	Ex db eb IIC T6/T4 Gb	
ATEX directive dusts	Ex tb IIIC T72°C/T104°C Db	
IECEx CoC	IECEx BKI 25.0010X	
IECEx directive gases	Ex db eb IIC T6/T4 Gb	
IECEx directive dusts	Ex tb IIIC T80°C/T130°C Db	
Max. torque ajustable	Nm	60-200 Nm
Power supply	V	24 VDC, optional 100-240 VAC, 24 VAC, 200-440 VAC
Power consumption	W	max. 150 W
Operating time/90° ajustable	s	6-20 sec
Duty cycle f IEC 60034-1,8	S2 - 30 min, S4 50% ED - 1200 c/h	
Ambient temperature	°C	-20°C to +60°C
Motor protection	Thermal monitoring with safety cut-off	
Enclosure	IP67	

Dimensions

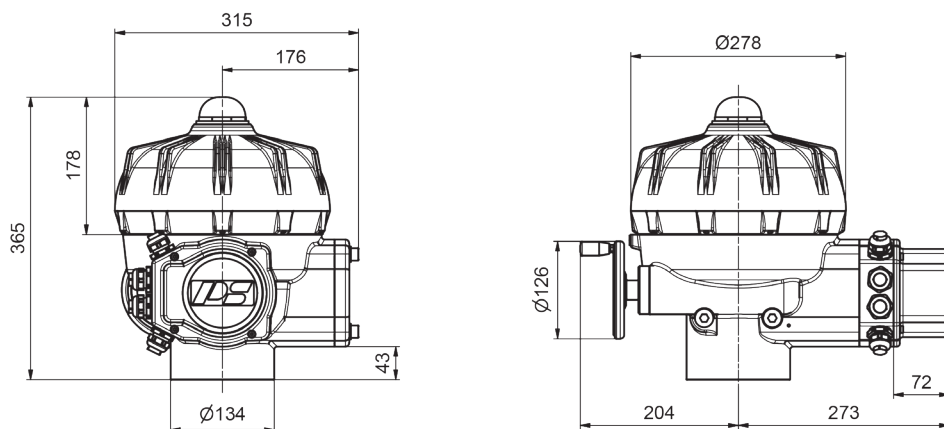

PS Automation GmbH

Philipp-Kraemer-Ring 13 • D-67098 Bad Dürkheim
+49 (0) 6322-94980-0 • info@ps-automation.com
www.ps-automation.com

Engineered and Made in Germany

