

# Intelligent Linear Actuator

**PSL204AMS12 -40°F**

Low Temperature Version

**Positioner integrated**

**758 lbf**

Max. thrust )<sup>1</sup>

**12.7 - 6.35 Secs/In.**

Stroke Speed

**max. 1.97 In.**

Stroke

Modulating actuator

Class C acc. to DIN EN ISO

22153

**Enclosure IP65**

acc. to EN 60529

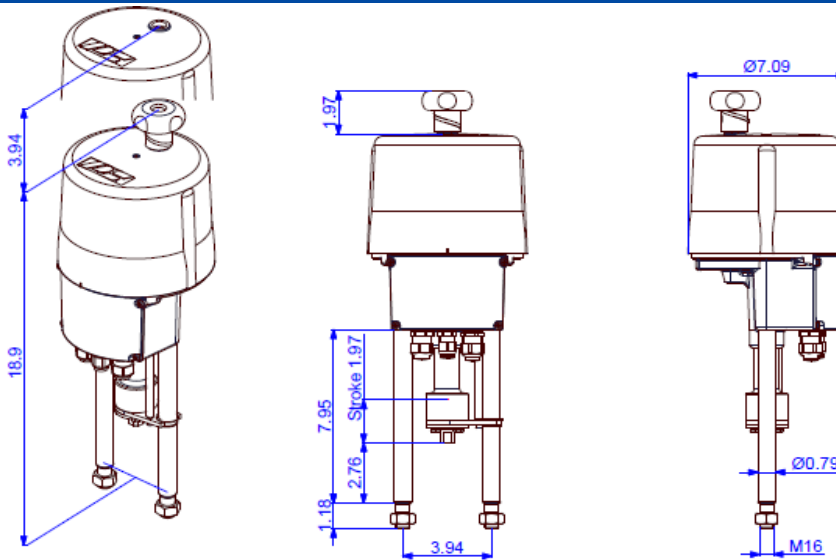

**Approx. weight: 17.7 lb without accessories** Dimensions are valid for connections M8-M12 only!

Stroke Speed	12.7 - 6.35 Secs/In. (adjustable)			
Power supply [V]	230 VAC 1~	115 VAC 1~	24 VAC/DC	360...575 VAC 3~ ) <sup>2</sup>
Nominal current ) <sup>3</sup> [A]	0.33	0.66	3.15(AC) / 2(DC)	
Max. current ) <sup>3</sup> [A]	0.43	0.86	4.1(AC) / 2.6(DC)	
Power consumption ) <sup>4</sup> [W]	57	57	53(AC) / 48(DC)	

**PSL204  
AMS12**

Standard	Description
Ambient temperature [°F]	<b>-40°F to +140°F</b>
Motor protection	Electronic motor current monitoring with safety cut-off
Overvoltage category	II
Break away force	Adjustable up to + 50% nominal force
Duty cycle as per IEC 60034-1,8	S2 30 min S4 50% ED @ 77°F
Control signal and feedback	0 (4)..20 mA or 0 (2)..10 V selectable, split range operation
Binary control	24 V - 230 V for ON/OFF control (min. duration of pulse 1s)
Valve positioner function	Integrated, deadband adjustable from 0.5 .. 5%, shut-off MIN
Automatic start-up	Recognizing the end position(s) and autoscaling set and feedback values
Internal fault monitoring	Thrust, control signal, temperature, power supply
Fault indication relay FIR	Standard, potential-free opening contact provides a freely definable (programmable) collective fault signal and doubles for indication for when
Diagnostics function	Stores cumulated operation data (motor and total running time, number of motor starts) and data sets of current values (set value, feedback value, torque, temperature and error messages)
Communication interface	Connecting to a USB port and a software, allows data reading and parametrisation
Conduit entries	2 pcs. M20 x 1,5 and 1 pcs. M16 x 1,5

**Standard equipment**

)<sup>1</sup> = permissible average force over the entire travel is 50% of the max. thrust

)<sup>2</sup> = max. input voltage range

)<sup>3</sup> = data may vary depending on accessories

)<sup>4</sup> = at max. thrust, data may vary depending on accessories

Wiring Termination

1-Phasen Wechselspannung / DC 1-Phase AC / DC																						3-Phasen 3-Phase AC								
1	2	3	4	5	6	7	8	9	10	11	12	13	14	15	16	17	18	19	20	21	22	23	L1	L2	L3	PE				
↕	↕	↕	↕	↕	↕	↕	↕	↕	↕	↕	↕	↕	↕	↕	↕	↕	↕	↕	↕	↕	↕	↕	↕	↕	↕	↕				
+0(2) -10V	+0(4) -20mA	GND	+0(4) -10V	+0(4) -20mA	GND	24 VDC	max. Last / max. Load 100 mA bei / at	L+ AUF/OPEN	N/-	L+ ZU/CLOSE	L+ (24V AC/DC - 230VAC)	N/- (24V AC/DC - 230VAC)	21 - 40 VDC / 100 mA	+0(2) -10V	+0(4) -20 mA	GND	(Option)	(Option)	(Option)	(Option)	L+ (siehe Typenschild/ see tag plate)	N/- (siehe Typenschild/ see tag plate)	PE	(Option)	RJ-45 TTL	Taster Button	400 VAC	400 VAC	400 VAC	Schutzleiter / protective conductor
Sollwert-Eingang	Aktive Positions-rückmeldung	Störmeldung potentialfrei	Binäre Ansteuerung	Netz-ausfall-signal	Ver-sorgung	Istwert	Zu / Closed	Auf / Open	Wegschalter potentialfreier Kontakt	Versorgungs-spannung	Feldbus-Anschluß	PC Kommunikation	Inbetrieb-nahme	Versorgungs-spannung	Set value input	Active position feedback	Monitor relay potential-free	Binary input signals	Fail safe signal	Actual value	Position switch potential-free contact	Power supply voltage	Fieldbus interface	PC communication	Commissioning	Power supply voltage	Schaltzettel			
Galvanisch getrennt / Galvanically isolated 1 kV																	8013770 - S-217_G													

Dimensions of the PS standard adaptation

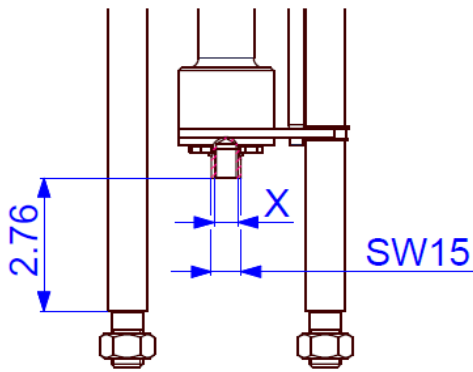

Connection Thread X

M8	Optional
M10	Optional
M12	Standard
M14	Optional
M16	Optional

Fine threaded and other sizes on request!

Mounting Position

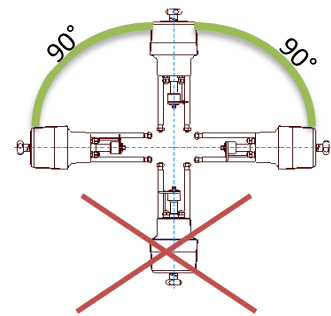

Dimensions are valid for connections M8-M12 only!

Accessories/Options		
Position signal switches, mechanical	2WE	2 potential-free position switches, mechanical, with silverplated changeover contacts, 24V to 230 V AC/DC @ 0.1A- 5A
Position signal switches gold, mechanical	2WE Gold	2 potential-free position switches, mechanical, with gold-plated changeover contacts 5 V to 30 V AC/DC @ 1mA- 100mA; contact resistance 30 mOhm
Integrated process controller	PSIC	Enables the autonomous control of a process so that an external controller is not required.
Fail-safe*	PSCP	Emergency power supply based on supercapacitors, safety position OPEN, CLOSED or free defined position
Fieldbus interface*		Digital transmission of nominal and actual value per mill or percent, report of monitoring and diagnostic data using Profibus DP (PSPDP) or CANOpen (PSCA) interfaces, additional interfaces available on request
Local control station	PSC.2	Illuminated display to show the actuator status and lockable selector to switch between modes: automatic, manual process ON/OFF, STOP and parameter menu. Control buttons for manual movement, menu operation and adjustment of parameters, display of diagnostic information
Remote local control		Mounting separately from the actuator (incl. 10 m connection cable)
Data cable	PSCS-USB	USB data cable enables the communication between the actuator and a PC by using the software PSCS
Fail-safe port*	FSP	Signal port to drive to a "safety position", selectable fail-safe position, standard 24 - 230 V
IP67		Increased enclosure IP67
Heating resistor	HR	Heating resistor to prevent condensation

\*not retrofittable

For more information and accessories, please visit our website [www.ps-automation.com](http://www.ps-automation.com)!

*Subject to changes!*